

# FRIGERIO

*Partner per professionisti*

## EUROTIS

Creatori di soluzioni



### Gas

Sistemi di tubazioni  
per impianti gas

CATALOGUE - PRICE LIST

 2022

Italiano - English







# La più vasta scelta di prodotti e soluzioni per i Professionisti

**Centro Artigiani e Industrie**  
**Centro Idro Termo Sanitario**  
**Centro Acciai e Edilizia**



*Partner per professionisti*

## Un team al fianco dei professionisti

Frigerio SA è da più di 95 anni il punto di riferimento per i professionisti. Un successo di una squadra equipaggiata ad affrontare ogni nuova sfida.

Siamo una squadra impegnata in uno sport molto competitivo, dato che come i migliori atleti, anche noi vogliamo spingerci oltre i nostri limiti per stabilire sempre nuovi record.

Viviamo con entusiasmo questo spirito perché siamo consapevoli che in ogni cantiere, laboratorio, officina, i professionisti si aspettano da Frigerio: uno staff altamente motivato, pronto in ogni momento a supportare il loro lavoro, uomini e donne che prestano la massima attenzione alle richieste e padroneggiano le conoscenze necessarie per soddisfarle.

Operiamo con successo da oltre novantacinque, perché con i professionisti condividiamo motivazioni e valori.

E un'inesauribile passione per tutto ciò che facciamo. Perché, come loro, sappiamo che ogni alto traguardo lo si raggiunge solo lavorando insieme, con 3 predisposizioni fondamentali:

qualità, professionalità e competenza.

Siamo in grado di capire a fondo le esigenze del cliente e anticipare le nuove tendenze, rinnovando, ottimizzando costantemente la gamma delle proposte e razionalizzando i costi.

**Frigerio: un grande team, una lunga storia, con la qualità sempre al primo posto!**

[www.frigerio.ch](http://www.frigerio.ch)

## Le soluzioni Eurotis

### Eurotis solutions



### Acqua

#### Water



Tubi CSST corrugati formabili in AISI 304- AISI 316L per la distribuzione di acqua calda e fredda sanitaria.

Pliable corrugated PLT-CSST tubes, in AISI 304 / AISI 316L stainless steel, suitable for drinking water.



Tubi CSST corrugati formabili in AISI 304 con rivestimento termico in polietilene espanso. Pliable corrugated PLT-CSST tubes in AISI 304 stainless steel with expanded polyethylene EPE coating.



### Solare

#### Solar



Tubi CSST corrugati formabili in acciaio inossidabile AISI 304 con rivestimento isolante termico per impianti solari termici.

AISI 304 stainless steel PLT-CSST tubes with insulation for thermal solar installations.



### Gas

#### Gas



Tubi CSST corrugati formabili in acciaio inossidabile AISI 316L per gas con rivestimento giallo in LDPE a norma UNI EN 15266.

Pliable corrugated PLT-CSST tubes in AISI 316L stainless steel for gas supply with LDPE yellow coating conform to EN 15266 standard.



### Raccordi

#### Fittings



Ampia gamma di raccordi per collegamento tra i componenti Eurotis, raccordi di transizione tra le nostre tubazioni CSST e qualsiasi terminale filettato (maschio o femmina), tubi in rame o apparecchiature con terminale in rame.

Wide range of fittings for the connection between either Eurotis tubes and every kind of copper tube threads (male or female) or other machinery with copper ends.



### Allacciamenti

#### Connections



Tubi flessibili, tubi flessibili estensibili e giunti elastici per gas in acciaio inox a norma UNI EN 14800 / UNI 11353 / UNI 9036.

Tubi flessibili estensibili e giunti elastici per acqua in acciaio inox.



Flexible hoses, flexible extensible hoses and elastic joints for gas in stainless steel according to EN 14800 / UNI 11353 / UNI 9036.

Flexible extensible hoses and elastic joints in stainless steel for water.



### Attrezzature

#### Tools



Vari attrezzi di flangiatura manuali e automatici, di pressatura, tagliatubi, dime e tutto il necessario per la lavorazione dei tubi CSST.

Various manual and automatic flanging tools, pressing tools, pipe cutter, templates and everything necessary for the processing of PLT-CSST tubes.

## Eurotis BIM library: l'intelligenza al servizio dell'innovazione

Eurotis ha scelto di sviluppare i propri sistemi di tubazioni corrugate formabili in acciaio inox CSST in oggetti BIM su base Autodesk Revit.

L'obiettivo di Eurotis non è più solo quello di fornire componenti, ma di fornire sistemi impiantistici e soluzioni innovative integrate. Per soddisfare questo proposito, oltre ad ampliare il portfolio prodotti, Eurotis offre ai progettisti la possibilità di inserire nei progetti i propri sistemi di tubazioni per impianti idrotermosanitari, solari termici e gas, in modo rapido ed efficiente.

La progettazione impiantistica MEP (Mechanical, Electrical and Plumbing) tramite BIM offre infatti numerosi vantaggi per ogni figura professionale coinvolta, dal progettista fino al gestore, rendendo il processo più rapido e completo. L'uso di software dedicati per la progettazione degli impianti tecnici ottimizza la qualità dell'esecuzione dei lavori e diminuisce l'impegno nella gestione degli stessi.

**Sul sito Eurotis è possibile scaricare in forma gratuita le nostre famiglie BIM. Configura e inserisci direttamente nel tuo progetto tubazioni e raccordi Eurotis.**

## *Eurotis BIM library: intelligence at the service of innovation*



Eurotis has chosen to develop its PLT-CSST pliable corrugated tube systems in BIM objects based on Autodesk Revit.

The goal of Eurotis is no longer simply to supply components, but also to provide building systems and integrated innovative solutions. To achieve this goal, Eurotis, in addition to expanding the product portfolio, offers designers a quick and efficient way to incorporate their own tube systems for plumbing, solar thermal and gas systems in their projects.

The MEP (Mechanical, Electrical and Plumbing) system design through BIM offers numerous benefits to all the professional figures involved, from the designer to the project manager, making the process faster and more comprehensive. The use of dedicated software for the design of technical systems optimises the quality of the project implementation and reduces the effort required to manage them.

**Our product lines are available for free download in BIM format on the Eurotis site. Configure and directly enter your Eurotis tubes and fittings project.**



# Sistemi di tubazioni CSST Eurotis

## *PLT-CSST tubing systems by Eurotis*



I sistemi di tubazioni Eurotis si basano sul tubo corrugato formabile in acciaio inossidabile austenitico AISI 304 e AISI 316L e sulla raccorderia in ottone studiata e realizzata per facilitarne l'installazione garantendone la massima tenuta.

La particolare struttura del tubo, resistente alla pressione e alla deformazione, permette di realizzare "a freddo" qualsiasi forma, con angoli fino a 180°, in totale assenza di attrezzi per la piegatura.

I sistemi di tubazioni CSST Eurotis sintetizzano le migliori tradizioni di affidabilità e solidità dei tubi in metallo con la praticità di installazione dei tubi corrugati.

I principali vantaggi sono:

- Velocità di posa nelle installazioni;
- Sagomatura manuale con raggi di curvatura molto contenuti senza deformazione della sezione;
- Leggerezza e robustezza;
- Mantenimento della forma assunta dopo la piegatura: è possibile preconstituire, anche in luoghi diversi dal cantiere, intere parti di impianto.

Eurotis systems are based on corrugated and pliable stainless steel AISI 304 and AISI 316L tubes and on brass fittings studied and realized to make easier the installation, obtaining the best tightness.

The particular structure of the tube, resistant to pressure and deformation, permits to realize every kind of shape with corners up to 180° without support of bending tools.

Eurotis PLT-CSST tubing systems summarize the best characteristics of reliability and solidity of metal tubes and the handiness in installation.

The main advantages are:

- Quickness in laying of the installations;
- Easiness in manual shaping with very small bending radius without the deformation of the section;
- Lightness and strength;
- Retention shape after bending: it is possible to assembly in advance and in sites different from the installation ones.

## Campi di applicazione

### *Application areas*

I campi di applicazione tipici delle tubazioni corrugate formabili CSST sono:

- **Impianti idrosanitari e riscaldamento**  
(completa idoneità al trasporto di acqua potabile);
- **Impianti solari termici**  
(resistenza alle alte temperature);
- **Impianti industriali**  
(vedere le tabelle di compatibilità chimica);
- **Impianti gas**  
(elevato livello di sicurezza a norma UNI EN 15266).

The typical applications of the corrugated pliable PLT-CSST tubes are:

- **Plumbing and heating systems**  
(full suitability for drinking water);
- **Thermal solar systems**  
(high temperature resistance);
- **Industrial systems**  
(see the tables for the chemical compatibility);
- **Gas systems**  
(high safety level conform to EN 15266 standard).

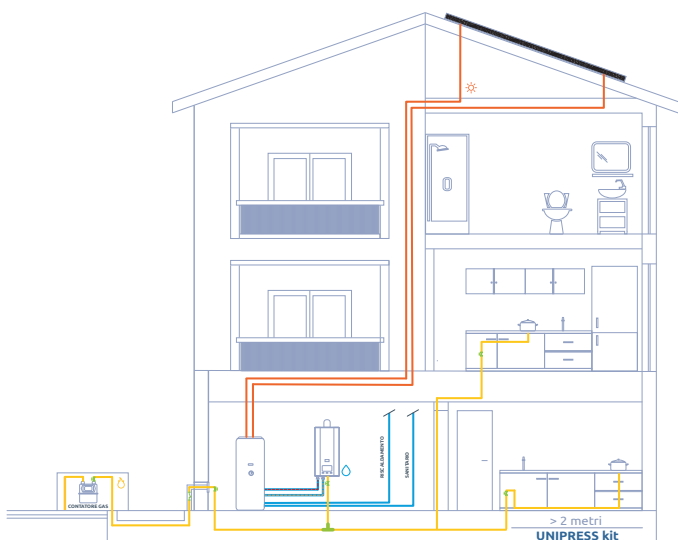

## Certificazioni

I sistemi di tubazioni corrugate formabili CSST di Eurotis sono certificati dai seguenti enti:

### SVGW

- Sistema per impianti gas a cartellare, doppio o-ring (certificato 19-011-6) ed ePRESS (certificato 19-012-6);
- Sistema per impianti acqua a cartellare (1905-6846).

### Kiwa

- EUROWATER per impianti idro-termo-sanitari (certificato n°KIP-096777) e riscaldamento (certificato n° KIP-096778);
- Twin Solar Set e Mono Sun Set per impianti solari termici (certificato n°KIP-096779);
- EUROGW e EUROGAS per impianti gas sono certificati UNI EN 15266 (certificato n°KIP-096291);
- ePRESS per impianti gas (certificato n°KIP-096877).

### DVGW

- EUROGW per impianti gas (certificato DG-4602CS0179);
- EUROGW per impianti acqua (certificato DW-7307BN6110);
- EUROGW per sistema ePRESS gas (certificato CG-4602CT0469);

Tutte queste certificazioni richiedono che il sistema (tubi, raccordi ed accessori) venga inizialmente sottoposto a prove di tipo ed in seguito periodicamente controllato con una serie di test di laboratorio per verificarne la continua conformità ai requisiti. Le certificazioni richiedono inoltre che il fabbricante del sistema attui un piano di controllo della produzione (mediante l'implementazione di procedure documentate, regolari ispezioni e prove sulle materie prime, i componenti del sistema, le apparecchiature di controllo, il processo di produzione ed il prodotto finale) per garantire che i prodotti immessi sul mercato rispettino i requisiti richiesti dalla norma, garantendo la loro rintracciabilità.

## Certifications

The pliable corrugated PLT-CSST tubing systems by Eurotis are certified by:

### SVGW

- For gas flanging, double o-ring (certificate 19-011-6) and ePRESS systems (certificate 19-012-6);
- For water flanging system (certificate 1905-6846).

### Kiwa

- EUROWATER for hydro-therm sanitary systems (certificate n°KIP-096777) and heating systems (certificate n°KIP-096778);
- Twin Solar Set e Mono Sun Set for thermal solar systems (certificate n°KIP-096779);
- EUROGW e EUROGAS for gas systems certified as for UNI EN 15266 (certificate n°KIP-096291);
- ePRESS for gas systems (certificate n°KIP-096877).

### DVGW

- EUROGW for gas systems (certificate DG-4602CS0179);
- EUROGW for water systems (certificate DW-7307BN6110);
- EUROGW for ePRESS gas systems (certificate CG-4602CT0469).

All these certifications require initial type tests for the tubing system (tubes, fittings and accessories) and then periodical laboratory tests to check its continuous conformity to the requirements. Moreover the manufacturer is required to establish, document, and maintain a factory production control (consisting in written procedures, regular inspections and tests to verify raw materials, components of the system, testing equipments, production process and finished product) to warrant the sold products and their traceability.



Sistema cartellare, doppio o-ring gas  
Flanging, double o-ring system gas  
SVGW 19-011-6



ePRESS / ePRESS systems gas  
SVGW 19-012-6



Sistema a cartellare acqua  
Flanging system water  
SVGW 1905-6846



## Tubazioni CSST *PLT-CSST tubes*



Eurotis ha sviluppato tre linee di tubazioni corrugate formabili in acciaio inox CSST studiate per l'installazione in impianti idrosanitari, di riscaldamento, solari termici e gas.

Eurotis produces three different lines of PLT-CSST tubes studied for plumbing, solar-thermal and gas installations.



### EUROWater

Tubi CSST corrugati formabili in AISI 304 / AISI 316L, per la distribuzione di acqua calda e fredda sanitaria. I tubi CSST in AISI 304 possono anche essere rivestiti in polietilene espanso, per l'utilizzo in impianti di riscaldamento.

Corrugated stainless steel tubes in AISI 304 and AISI 316L for sanitary water distribution. AISI 304 tubes can be coated with EPE insulation for heating installations.



### EUROSolar

Tubi CSST corrugati formabili in AISI 304 con rivestimento isolante termico per impianti solari.

Corrugated stainless steel tubes in AISI 304 with thermal insulation coating for solar installations.



### EUROgas

Tubi CSST corrugati formabili in AISI 316L con rivestimento giallo in LDPE a norma UNI EN 15266, per impianti gas.

Corrugated stainless steel tubes in AISI 316L with LDPE coating conform to EN 15266 standard for gas installations.

## Temperatura e pressione di esercizio delle tubazioni CSST

### Working temperature and pressure of PLT-CSST tubing systems

La massima temperatura di esercizio dei sistemi CSST dipende da molti fattori e principalmente:

- materiale dei componenti del sistema;
- tubi corrugati formabili CSST in acciaio inossidabile
- AISI 304 o AISI 316L;
- raccordi in ottone CW614N / CW617N;
- elementi di tenuta: vedere il prospetto a pagina 42 in funzione del materiale specifico;
- materiale dell'eventuale rivestimento esterno.

La massima pressione di esercizio dei tubi CSST è in funzione della massima temperatura di esercizio dell'impianto.

The maximum operative temperature of the PLT-CSST system depends on many factors and mainly:

- system components material;
- PLT-CSST pliable corrugated tubes in AISI 304 or AISI 316L stainless steel;
- fittings in CW614N / CW617N brass;
- sealing elements: see table at page 42 in function of their specific material;
- material of the external coating (if any).

The maximum operative pressure of the PLT-CSST tubes is in function of the operative temperature of the plant.

### Temperatura di esercizio in continuo

#### Continuous operative temperature

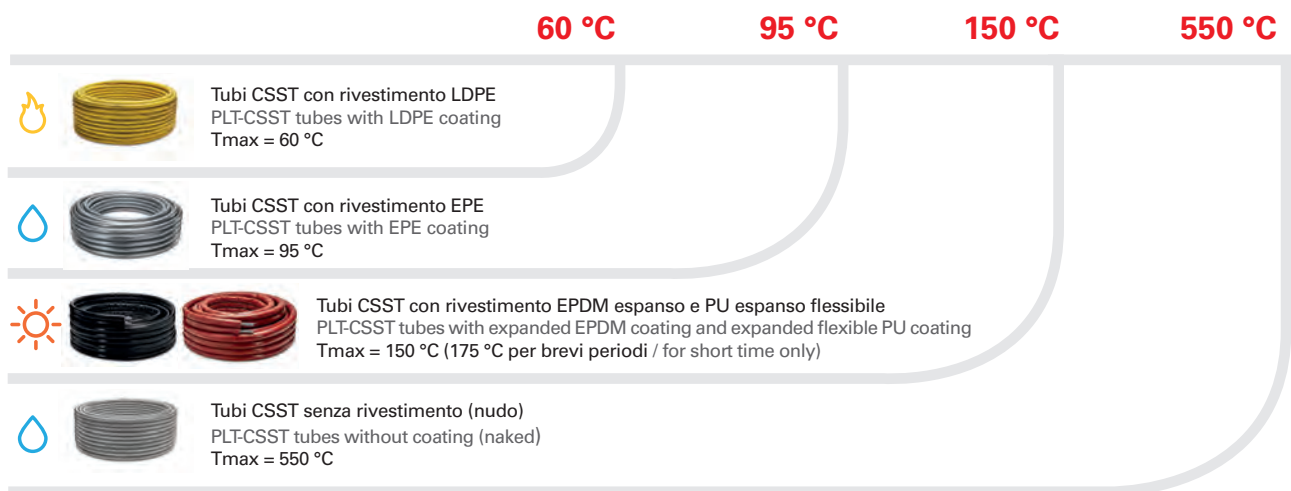

### Pressione / temperatura di esercizio tubi CSST

#### Operative pressure / temperature PLT-CSST tubes

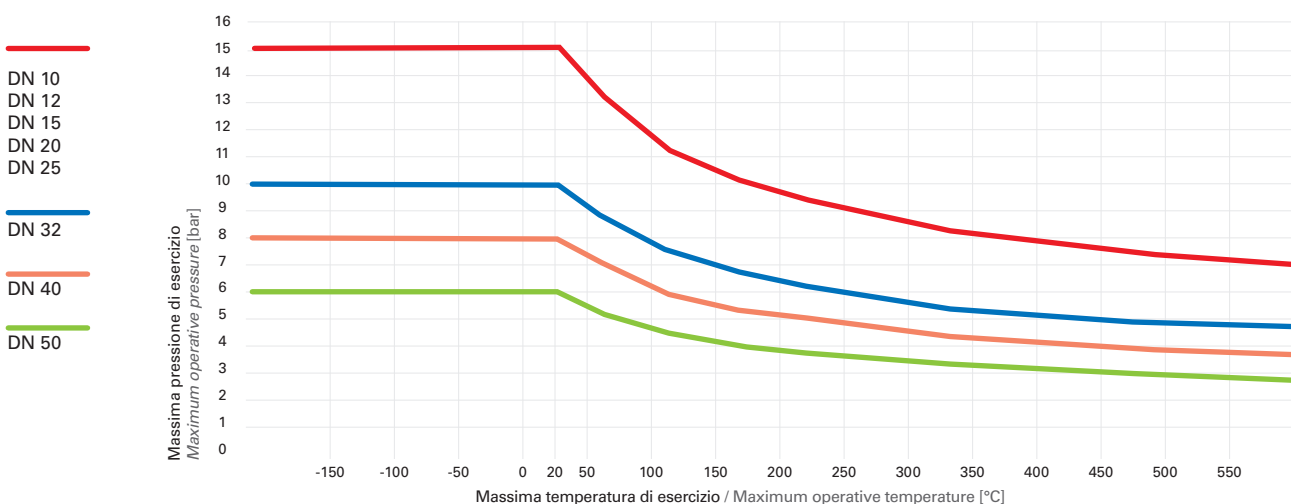

## Compatibilità chimica delle tubazioni CSST

### Chemical compatibility of PLT-CSST tubing systems

Sostanza / Substance	AISI 304	AISI 316L	Sostanza / Substance	AISI 304	AISI 316L	Sostanza / Substance	AISI 304	AISI 316L
Acetilene / Acetylene	A	A	Borace / Borax	A	A	Mostarda / Mustard	A	A
Aceto (liquido) / Vinegar (liquid)	A	A	Bromo / Bromine	C	C	Nafta / Naphtha	A	A
Aceto (vapori) / Vinegar (vapour)	B	A	Butano / Butane	A	A	Nitrato di ammonio Ammonium nitrate	A	A
Acetone / Acetone	A	A	Caffè / Coffee	A	A	Nitrato di sodio / Sodium nitrate	A	A
Acido acetico / Acetic acid	B	B	Canfora / Camphor	A	A	Olii minerali / Mineral oils	A	A
Acido bórico / Boric acid	A	A	Carbonato di sodio Sodium carbonate	A	A	Olii vegetali / Vegetal oils	A	A
Acido butirrico / Butyric acid	A	A	Catrame / Tar	A	A	Ossigeno / Oxygen	A	A
Acido cianidrico / Hydrocyanic acid	B	B	Citrato di sodio / Sodium citrate	A	A	Paraffina / Paraffin	A	A
Acido citrico / Citric acid	A	A	Cloro (anidro) / Chlorine (dry)	C	B	Perborato di sodio Sodium perborate	B	B
Acido cloridrico / Hydrochloric acid	C	C	Cloro (umido) / Chlorine (moist)	C	C	Perossido di idrogeno Hydrogen peroxide	A	A
Acido cromico / Chromic acid	A	A	Cloroformio / Chloroform	A	A	Perossido di sodio / Sodium peroxide	B	B
Acido fluoridrico / Hydrofluoric acid	C	C	Cloruro di alluminio Aluminium chloride	C	C	Piombo (fuso) / Lead (molten)	B	B
Acido fosforico / Phosphoric acid	B	B	Cloruro di ammonio Ammonium chloride	A	A	Propano / Propane	A	A
Acido lattico / Lactic acid	A	A	Cloruro di ferro / Iron chloride	C	C	Sapone / Soap	A	A
Acido linoleico / Linoleic acid	B	A	Cloruro di magnesio Magnesium chloride	C	C	Sciropo di zucchero / Sugar syrup	A	A
Acido malico / Malic acid	A	A	Cloruro di potassio Potassium chloride	A	A	Siero di latte / Milk whey	A	A
Acido muriatico / Muriatic acid	C	C	Cloruro di sodio / Sodium chloride	A	A	Silicco di sodio / Sodium silicate	A	A
Acido nitrico / Nitric acid	B	B	Cloruro di zinco / Zinc chloride	B	A	Solfato d'alluminio Aluminium sulphate	A	A
Acido oleico / Oleic acid	A	A	Cloruro di zolfo / Sulphur chloride	A	A	Solfato d'ammonio Ammonium sulphate	C	B
Acido ossalico / Oxalic acid	C	C	Cloruro mercurico Mercuric chloride	C	C	Solfato di bario / Barium sulphate	B	B
Acido picrico / Picric acid	A	A	Eteri / Ethers	A	A	Solfato di calcio / Calcium sulphate	A	A
Acido solfidrico / Hydrogen sulphide	B	A	Formaldeide / Formaldehyde	A	A	Solfato di magnesio Magnesium sulphate	A	A
Acido solforico (vetriolo) Sulphuric acid (vitriol)	B	B	Fosfato d'ammonio Ammonium phosphate	B	B	Solfato di nichel / Nickel sulphate	A	A
Acido solforoso / Sulphurous acid	B	B	Fosfato di sodio / Sodium phosphate	B	B	Solfato di potassio Potassium sulphate	A	A
Acido stearico / Stearic acid	A	A	Furfurolo / Furfurolo	A	A	Solfato di rame / Copper sulphate	B	A
Acido tartarico / Tartaric acid	A	A	Gas di città / City gas	A	A	Solfato di sodio / Sodium sulphate	A	A
Acqua carbonata / Carbonated water	A	A	Gas di cloro (umido) Chlorine gas (moist)	C	C	Solfato di zinco / Zinc sulphate	A	A
Acqua dolce / Fresh water	A	A	Gas di cokeria / Coke gas	A	A	Solfato ferrico / Ferric sulphate	A	A
Acqua marina / Salt water	C	C	Gelatina / Gelatine	A	A	Solfato ferroso / Ferrous sulphate	B	B
Acqua ossigenata Hydrogen peroxide	A	A	Glicerina / Glycerin	A	A	Solfuro di sodio / Sodium sulphide	B	A
Acqua ragia / Aqua regia	A	A	Glicole etilenico / Ethyl glycol	A	A	Succhi di agrumi / Citrus fruit juices	A	A
Alcool etilico / Ethyl alcohol	A	A	Glucosio / Glucose	A	A	Tetracloruro di carbonio (anidro) Carbon tetrachloride (dry)	A	A
Alcool metilico / Methyl alcohol	A	A	Gomma lacca / Shellac	A	A	Tetracloruro di carbonio (umido) Carbon tetrachloride (moist)	C	C
Alluminio (fuso) / Aluminium (molten)	C	C	Idrossido d'ammonio Ammonium hydroxide	A	A	Tiosolfato di sodio Sodium tiosulphate	B	A
Ammoniaca / Ammonia	A	A	Idrossido di bario / Barium hydroxide	B	A	Toluene / Toluolo	A	A
Anidride acetica / Acetic anhydride	A	A	Idrossido di calcio Calcium hydroxide	B	B	Tricloroetilene (triellina) Trichloroethylene	B	B
Anidride carbonica / Carbon dioxide	A	A	Idrossido di magnesio Magnesium hydroxide	B	B	Vapore acqueo / Water steam	A	A
Anidride solforosa Sulphurous anhydride	C	B	Idrossido di potassio Potassium hydroxide	B	B	Vernici / Varnishes	A	A
Anilina / Aniline	A	A	Idrossido di sodio Sodium hydroxide	B	B	Vino / Wine	A	A
Argo / Argon	A	A	Ipcolorito di calcio Calcium hypochlorite	C	C	Whisky / Whisky	A	A
Azoto / Nitrogen	A	A	Ipcolorito di sodio (candeggina) Sodium hypochlorite (bleach)	C	B	Zinco (fuso) / Zinc (molten)	C	C
Bagni di concia / Tanning baths	A	A	Latte / Milk	A	A	Zolfo (fuso) / Sulphur (molten)	A	A
Bagni di cromatura / Plating baths	A	A	Lievito / Leaven	A	A			
Bagni di fissaggio fotografico Photograph fixing baths	A	A	Maionese / Mayonnaise	A	A			
Bagni di sviluppo fotografico Photograph development baths	A	A	Melassa / Molasses	A	A			
Benzene / Benzene	A	A	Mercurio / Mercury	A	A			
Benzina / Gasoline (petrol)	A	A	Metano / Methane	A	A			
Benzene - benzolo / Benzene	A	A						
Bicarbonato di sodio Sodium bicarbonate	A	A						
Birra / Beer	A	A						
Bisolfuro di carbonio Carbon disulfide	A	A						
Bisolfato di sodio / Sodium disulphate	C	C						

#### LEGENDA / LEGEND

- A** Nessun pericolo di corrosione  
No corrosion risk
- B** Possibilità di corrosione: verificare le condizioni di impiego  
Possible corrosion: check use conditions
- C** Pericolo di corrosione  
Risk of corrosion

## Perdite di carico Pressure drops

### Perdite di carico tubi CSST (acqua) PLT-CSST tubes pressure drops (water)

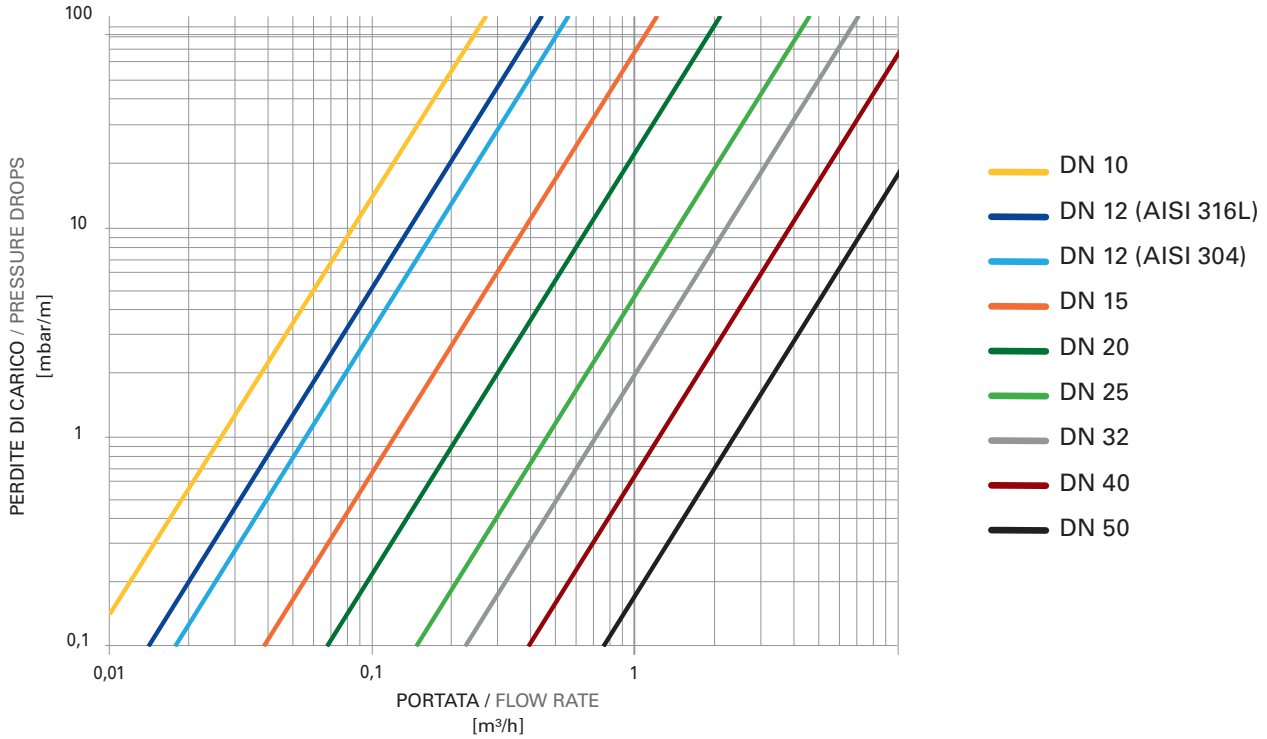

### Perdite di carico tubi CSST (aria) PLT-CSST tubes pressure drops (air)

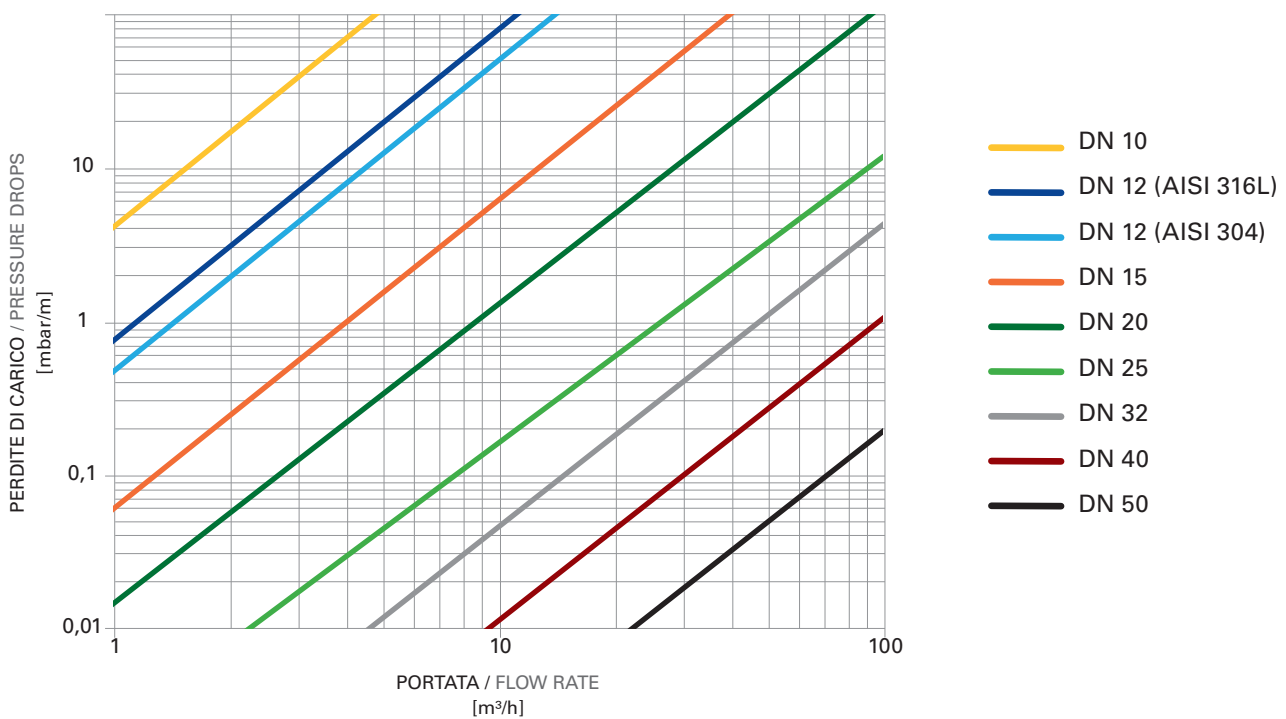

# Sistemi di giunzione

## Connection systems



Eurotis propone una serie di elementi di giunzione per collegare:

- due o più tubazioni CSST (con diametri uguali o differenti);
- tubazioni CSST a terminali filettati maschi o femmina;
- tubazioni CSST e tubi o apparecchiature con terminali in rame.

La particolare struttura del tubo, resistente alla pressione e alla deformazione e lo spessore minimo di 0,3 mm hanno reso unici i sistemi di tubazioni Eurotis.

Gli elementi di giunzione sono stati studiati sulla particolare morfologia delle tubazioni Eurotis.

Ecco perché per le giunzioni tra i componenti del sistema di tubazioni CSST di Eurotis ed altri sistemi o materiali si devono utilizzare unicamente raccordi e componenti forniti da Eurotis, anche per garantire la tenuta e l'antisfilamento. Le dimensioni (diametri interni ed esterni, passo delle corrugazioni, spessore, etc.) dei tubi CSST sono diverse per ogni fabbricante e non è quindi possibile utilizzare i raccordi di un diverso produttore.

Eurotis offers different connection systems modalities:

- connection between PLT-CSST tubes (with same DN or different DN);
- connection between a PLT-CSST tube and male or female thread end;
- connection between a PLT-CSST tube and copper tubes.

The particular structure of the tube, resistant to pressure and deformation and the minimum thickness of 0.3 mm have made Eurotis' piping systems unique. The connection systems have been studied on the particular morphology of Eurotis tubes. This is why only fittings and components supplied by Eurotis must be used for the joints between the components of the Eurotis PLT-CSST tubing system and other systems or materials, also to assure the tightness and the resistance to pull out.

The dimensions (interior and external diameters, pitch of the corrugations, thicknesses, etc.) of the PLT-CSST tubes are different from manufacturer to manufacturer and so it is not possible to use the fitting of other manufacturer with the PLT-CSST tubes of another one.

Nei sistemi di Eurotis la tenuta delle giunzioni tra tubo CSST e raccordo è garantita da:

In Eurotis systems the tightness of the connection between PLT-CSST tube and fitting is assured by:

### Sistema a cartellare

Tenuta assicurata da guarnizione piana (con questa tipologia di raccordi i tubi CSST devono essere preventivamente flangiati).

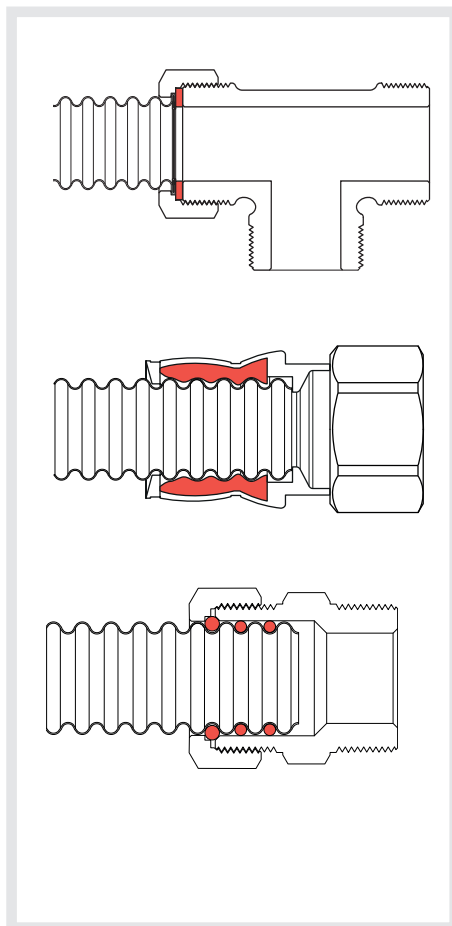

### Flanging system

The tightness is made possible using a plane gasket (PLT-CSST tube need to be previously flanged).

### Sistema a pressare

Tenuta della giunzione ottenuta mediante la compressione del raccordo sul tubo CSST.

### Press-fitting system

The tightness is assured thanks to the compression of the fitting (and the gasket inside it) on the PLT-CSST tube.

### Sistema a doppio o-ring

Tenuta assicurata da doppio o-ring ed anello di tenuta in ottone.

### Double o-ring system

The tightness is made possible using 2 o-rings (PLT-CSST tube don't need to be flanged).

La raccorderia di Eurotis è fornita con elementi di tenuta in materiali idonei e specifici per differenti temperature di esercizio e fluido da trasportare.

The fittings by Eurotis are supplied with sealing elements in proper and specific materials for different working temperature and conveyed fluid.

**Tutti i sistemi sono a passaggio totale.**

**All systems are total passage systems.**

## Sistema a cartellare Flanging system



Da DN 10 a DN 50



Manuale - Manual  
Cod. A06-0001-02395



Automatica - Automatic  
Cod. A06-0001-04610



### ADAPTOR

Semi-automatica  
Semi-automatic  
Cod. A06-0001-05156



### XLADAPTOR

Semi-automatica  
Semi-automatic  
Cod. A06-0001-05464

Il sistema a cartellare, molto utilizzato nel settore idro-termosanitario, è il sistema Eurotis che, grazie all'Azienda, ha fatto la storia del tubo CSST.

La tenuta meccanica, tubo/raccordo, avviene grazie alla compressione delle ultime due corrugazioni del tubo CSST, questo procedimento crea una battuta piana denominata flangia. L'alta resistenza della flangia creata sul tubo CSST Eurotis è dovuta allo spessore di 0,30 mm.

Il sistema a cartellare Eurotis **è stato progettato e sviluppato per tubi di diversi diametri, dal DN 10 al DN 50**, per soddisfare tutte le esigenze impiantistiche.

Per effettuare la flangiatura (cartellatura) dei tubi CSST, Eurotis mette a disposizione dell'installatore tre attrezzature: **automatica, manuale o semi-automatica (ADAPTOR)**.

L'ADAPTOR, brevettato Eurotis e primo ed unico strumento di flangiatura semi-automatica compatibile con tutte le macchine pressatrici standard (non mini), è stato studiato anche nella sua versione XL per i grandi diametri (da DN 32 a DN 50).

Per realizzare la flangia, indipendentemente dall'attrezzatura Eurotis che viene utilizzata, devono essere impiegate le apposite dime realizzate nei diversi diametri.

**La tenuta idraulica è garantita da diversi tipi di guarnizioni piane:** Klingersil, Afm34, Centellen, EPDM, Grafite per acqua e solare e NBR per gas. Inoltre, i dadi del sistema sono costruiti con una speciale sede che ne ottimizza la tenuta.

The flanging system, widely used in the hydro-thermo-sanitary sector, is the Eurotis system which, thanks to the company, has made the history of the PLT-CSST tube. The mechanical seal, tube / fitting, takes place thanks to the compression of the last two corrugations of the PLT-CSST tube, this procedure creates a flat ledge called flange.

Thanks also to the thickness of the Eurotis tube, equal to 0.3 mm, the mechanical seal is ensured by the folder of the corrugations which generates a flange with considerable resistance. The Eurotis flanging system **has been designed and developed for tubes of different diameters, from DN 10 to DN 50**, to satisfy all plant requirements.

To carry out the flanging of the PLT-CSST tubes, Eurotis provides the installer with three equipment: **automatic, manual or semi-automatic (ADAPTOR)**.

The ADAPTOR, a Eurotis patent and the first and only semi-automatic flanging tool compatible with all standard (not mini) pressing machines, has also been studied in its XL version for large diameters (from DN 32 to DN 50).

To make the flange, independently of the Eurotis equipment that is used, the special templates for the different diameters must be used. The hydraulic seal is guaranteed by different types of flat gaskets: Klingersil, Afm34, Centellen, EPDM, Graphite for water and solar and NBR for gas. Furthermore, the system nuts are built with a special seat that optimizes the seal.

## Sistema a pressare Press-fitting system



Da DN 12 a DN 25

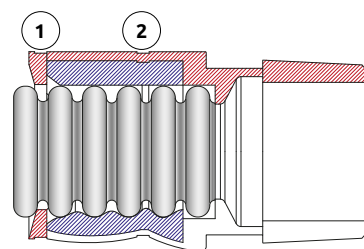

**Il 1° punto deforma l'ingresso del raccordo** dove è presente un "dente" che, ad avvenuta pressatura, blocca il tubo inserendosi nella gola della corrugazione impedendone lo sfilamento.

**Il 2° punto di pressatura deforma la guarnizione**, permettendone la penetrazione all'interno delle corrugazioni del tubo CSST e garantendo una tenuta idraulica sicura e duratura.

**The 1st point deforms the entrance of the fitting** where there is a "tooth" which, after pressing, locks the tube and inserts itself in the last corrugation preventing it from slipping off.

**2nd pressing point deforms the gasket**, allowing it to penetrate into the corrugations of the PLT-CSST tube and ensuring a secure and lasting seal.

Nella piena conformità delle normative vigenti, EUROTIS presenta il primo sistema brevettato a pressare per tubi corrugati CSST. Il sistema utilizza l'innovativa ePRESS Technology e sintetizza le migliori tradizioni di affidabilità, flessibilità e sicurezza dei tubi corrugati CSST Eurotis con la praticità e velocità di installazione del sistema a pressare.

### Rapidità e facilità di installazione

È possibile lavorare e piegare manualmente il tubo CSST senza l'utilizzo di specifiche attrezzature. Questo risulta possibile grazie alla specifica morfologia delle corrugazioni e ad uno spessore di 0,3 mm che conferiscono alla tubazione massimo rendimento in fase di piegatura.

### Qualità della tenuta

La tenuta della giunzione (tubo/raccordo) è garantita da due punti di pressatura.

Tutti i raccordi ePRESS sono realizzati in ottone, all'interno in base al campo di applicazione del raccordo possiamo trovare o una guarnizione nera in EPDM PEROX idonea al trasporto di acqua potabile e resistente fino a temperature operative continue di 150 °C oppure una guarnizione gialla in HNBR a norma EN 682 idonea al trasporto di gas.

In full compliance with the regulations in force, EUROTIS srl presents the first patented press-fitting system for corrugated tubes PLT-CSST. The ePRESS Technology summarizes the best traditions of reliability, flexibility and safety of the Eurotis PLT-CSST corrugated tubes with the practicality and speed of installation of the pressing system.

### Quick and easy installation

It is possible to manually process and bend the PLT-CSST tube without using specific tools. This is possible thanks to the specific morphology of the corrugations and to a minimum thickness of 0.3 mm which give the pipe the maximum performance during bending.

### Seal quality:

The seal of the joint (pipe / fitting) is guaranteed by two pressing points.

All ePRESS fittings are made of brass, with a yellow HNBR gasket in accordance with EN 682 suitable for the transport of gas or EPDM PEROX gasket suitable for transporting drinking water and resistant up to 150 °C continuous operating temperatures.



## Sistema a doppio o-ring *Double o-ring system*



Da DN 12 a DN 50



Il sistema doppio o-ring è stato studiato per garantire una lavorazione semplice e intuitiva priva di attrezzature dedicate.

La speciale corrugazione del CSST permette l'inserimento di due o-ring all'interno delle prime due gole del tubo (tenuta idraulica) e di un anello metallico nella terza gola (tenuta meccanica)

La tenuta idraulica è garantita per l'applicazione gas da due o-ring in NBR a norma EN 682, mentre per le applicazioni acqua/solare con un'o-ring in EPDM e una seconda o-ring in FKM. La guarnizione FKM è rinomata per la sua resistenza alle alte temperature.

Il sistema a doppio o-ring è stato studiato e realizzato per tubi che vanno dal DN 12 al DN 50.

The double O-rig system has been studied to guarantee a processing without dedicated equipment in a simple and intuitive way.

The special corrugation of the PLT-CSST allows the insertion of two o-rings inside the first two grooves of the hose (hydraulic seal) and in the third groove a metal ring (mechanical seal).

The hydraulic seal is guaranteed for the application of gas from two o-rings in NBR according to EN 682, while for water applications it is solar powered with an o-ring in EPDM and a second o-ring in FKM. The FKM gasket is renowned for its resistance to high temperatures, while the EPDM gasket for high performance in the hydraulic seal

The double o-ring system has been designed and built for tubes ranging from DN 12 to DN 50.

## EUROgas



### Tubazioni per impianti gas Tubes for gas installations

Da DN 12 a DN 50



Tubi CSST in acciaio inossidabile AISI 316L con rivestimento protettivo giallo in LDPE a norma UNI EN 15266 per impianti gas

*Pliable corrugated PLT-CSST tubes in AISI 316L stainless steel for gas supply with LDPE protective yellow coating conform to EN 15266 standard*



SVGW SSGE	Codice Code	DN	Fil. connessione Connection thread	Spessore acciaio Steel thickness	Lungh./confezione Length / box	CHF/conf. CHF/pack	CHF/metro CHF/meter	Conf./box Packs/box
	A01-0001-00691	12	1/2"	0,30 mm	5 m	<b>73,30</b>	14,66	20
	A01-0001-00692	12	1/2"	0,30 mm	10 m	<b>146,60</b>	14,66	10
	A01-0001-00693	12	1/2"	0,30 mm	25 m	<b>365,80</b>	14,63	5
	A01-0001-00694	12	1/2"	0,30 mm	50 m	<b>731,60</b>	14,63	-
	A01-0001-01768	12	1/2"	0,30 mm	100 m	<b>1.463,00</b>	14,63	-
	A01-0001-00697	15	3/4"	0,30 mm	5 m	<b>94,20</b>	18,84	15
	A01-0001-00698	15	3/4"	0,30 mm	10 m	<b>188,00</b>	18,80	8
	A01-0001-00699	15	3/4"	0,30 mm	25 m	<b>469,00</b>	18,76	-
	A01-0001-00700	15	3/4"	0,30 mm	50 m	<b>937,90</b>	18,76	-
	A01-0001-01769	15	3/4"	0,30 mm	100 m	<b>1.875,90</b>	18,76	-
	A01-0001-00703	20	1"	0,30 mm	5 m	<b>131,00</b>	26,20	10
	A01-0001-00704	20	1"	0,30 mm	10 m	<b>262,00</b>	26,20	5
	A01-0001-00705	20	1"	0,30 mm	25 m	<b>655,00</b>	26,20	-
	A01-0001-00706	20	1"	0,30 mm	50 m	<b>1.311,90</b>	26,24	-
	A01-0001-01770	20	1"	0,30 mm	100 m	<b>2.620,00</b>	26,20	-
	A01-0001-00707	25	1" 1/4	0,30 mm	5 m	<b>159,20</b>	31,84	5
	A01-0001-00708	25	1" 1/4	0,30 mm	10 m	<b>318,10</b>	31,81	-
	A01-0001-00709	25	1" 1/4	0,30 mm	25 m	<b>795,20</b>	31,81	-
	A01-0001-00710	25	1" 1/4	0,30 mm	50 m	<b>1.590,80</b>	31,82	-
	A01-0001-04216	32	1" 1/2	0,35 mm	10 m	<b>381,80</b>	38,18	-
	A01-0001-04219	32	1" 1/2	0,35 mm	30 m	<b>1.145,30</b>	38,18	-
-	A01-0001-04217	40	2"	0,35 mm	10 m	<b>450,60</b>	45,06	-
-	A01-0001-04220	40	2"	0,35 mm	30 m	<b>1.351,60</b>	45,05	-
-	A01-0001-04218	50	2" 1/2	0,40 mm	10 m	<b>563,30</b>	56,33	-
-	A01-0001-04221	50	2" 1/2	0,40 mm	30 m	<b>1.689,40</b>	56,31	-



## Tubi CSST EUROGAS in acciaio inox AISI 316L con rivestimento stellare

*AISI 316L EUROGAS stainless steel PLT-CSST tubes with stellar coating*



Codice Code	DN	Fil. connessione Connection thread	Spessore acciaio Steel thickness	Lungh./confezione Length / box	CHF/confez. CHF/pack	CHF/metro CHF/meter	Conf./box Packs/box
A01-0001-00695	12	1/2"	0,30 mm	25 m	<b>465,90</b>	18,64	-
A01-0001-00696	12	1/2"	0,30 mm	50 m	<b>931,80</b>	18,64	-
A01-0001-00701	15	3/4"	0,30 mm	25 m	<b>562,90</b>	22,52	-
A01-0001-00702	15	3/4"	0,30 mm	50 m	<b>1.125,40</b>	22,51	-

## Sistemi di giunzione per impianti gas

### Connection systems for gas installations



### Sistema a cartellare

#### Flanging system



### Raccordi per sistema a cartellare

#### Fittings for flanging system

Da DN 12 a DN 25



Dadi in ottone nichelato a sede speciale con filettatura femmina ISO 228 G senza guarnizioni

Nickel plated brass nuts with special seat and ISO 228 G female thread without gaskets

Codice Code	DN	Fil. connessione Connection thread	Pz./conf. Pcs./pack	CHF/confez. CHF/pack	CHF/Pz. CHF/Pcs	Conf./box Packs/box
A02-0010-00746	12	G 1/2"	10	15,00	1,50	-
A02-0010-00747	15	G 3/4"	10	23,60	2,36	-
A02-0010-00748	20	G 1"	10	38,40	3,84	-
A02-0010-00749	25	G 1" 1/4	10	62,40	6,24	-



Viti semplici di unione in ottone con filettatura maschio ISO 228 G senza guarnizioni

Brass connection simple screws with ISO 228 G male thread without gaskets

Codice Code	DN	Fil. connessione Connection thread	Pz./conf. Pcs./pack	CHF/confez. CHF/pack	CHF/Pz. CHF/Pcs	Conf./box Packs/box
A03-0010-01384	12	G 1/2"	10	20,60	2,06	-
A03-0010-01385	15	G 3/4"	10	32,10	3,21	-
A03-0005-01386	20	G 1"	5	31,90	6,37	-
A03-0005-01387	25	G 1" 1/4	5	60,60	12,12	-



**Dadi in ottone nichelato a sede speciale con filettatura femmina ISO 228 G a battuta piana e guarnizioni piane in NBR a norma EN 682 per gas**

*Nickel plated brass nuts with special seat and ISO 228 G female thread with NBR plane gaskets conform to EN 682 standard for gas*

Codice Code	DN	Fil. connessione Connection thread	Pz./conf. Pcs./pack	CHF/confez. CHF/pack	CHF/Pz. CHF/Pcs	Conf./box Packs/box
A02-0010-01828	12	G 1/2"	10	<b>16,90</b>	1,69	20
A02-0010-01829	15	G 3/4"	10	<b>25,40</b>	2,54	10
A02-0010-01830	20	G 1"	10	<b>41,10</b>	4,11	-
A02-0010-01831	25	G 1" 1/4	10	<b>66,10</b>	6,61	-

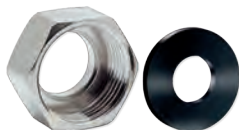

**Dadi ridotti in ottone nichelato a sede speciale con filettatura femmina ISO 228 G a battuta piana e guarnizioni piane in NBR a norma EN 682 per gas**

*Reduced nickel plated brass nuts with special seat and ISO 228 G female thread with NBR plane gaskets conform to EN 682 standard for gas*

Codice Code	DN	Fil. connessione Connection thread	Pz./conf. Pcs./pack	CHF/confez. CHF/pack	CHF/Pz. CHF/Pcs	Conf./box Packs/box
A02-0010-01890	12	G 3/4"	10	<b>45,30</b>	4,53	-
A02-0010-01891	15	G 1"	10	<b>57,60</b>	5,76	-
A02-0010-01892	20	G 1" 1/4	10	<b>91,80</b>	9,18	-



**Viti semplici ridotte in ottone con filettatura maschio ISO 228 G a battuta piana e guarnizioni piane in NBR a norma EN 682 per gas**

*Reduced brass simple screws with ISO 228 G male thread (with plane end) with NBR plane gaskets conform to EN 682 for gas*

Codice Code	DN	Fil. connessione Connection thread	Pz./conf. Pcs./pack	CHF/confez. CHF/pack	CHF/Pz. CHF/Pcs	Conf./box Packs/box
A03-0010-01953	12	G 3/4"	10	<b>42,30</b>	4,23	-
A03-0005-01954	15	G 1"	5	<b>38,10</b>	7,61	-
A03-0005-01955	20	G 1" 1/4	5	<b>74,50</b>	14,90	-



**Nipplo M/M in ottone nichelato con doppia filettatura maschio ISO 228 G a battuta piana (A-B)**

*Nickel plated brass M/M nipples with double ISO 228 G male thread with plane end*

Codice Code	DN	Fil. connessione Connection thread		Pz./conf. Pcs./pack	CHF/confez. CHF/pack	CHF/Pz. CHF/Pcs	Conf./box Packs/box
		A	B				
A03-0010-00773	12	G 1/2"	G 1/2"	10	<b>34,70</b>	3,47	15
A03-0010-00774	15	G 3/4"	G 3/4"	10	<b>52,20</b>	5,22	10
A03-0005-00775	20	G 1"	G 1"	5	<b>51,40</b>	10,28	-
A03-0005-00776	25	G 1" 1/4	G 1" 1/4	5	<b>96,10</b>	19,23	-



**Nipplo M/M in ottone con doppia filettatura maschio ISO 228 G a battuta piana (A-B)**

*Brass M/M nipples with ISO 228 G male thread with plane end*

Codice Code	DN	Fil. connessione Connection thread		Pz./conf. Pcs./pack	CHF/confez. CHF/pack	CHF/Pz. CHF/Pcs	Conf./box Packs/box
		A	B				
A03-0010-00777	12	G 1/2"	G 1/2"	10	<b>34,40</b>	3,44	-
A03-0010-00778	15	G 3/4"	G 3/4"	10	<b>50,60</b>	5,06	-
A03-0005-00779	20	G 1"	G 1"	5	<b>51,20</b>	10,24	-
A03-0005-00780	25	G 1" 1/4	G 1" 1/4	5	<b>115,00</b>	23,00	-



**Nipplo M/M in ottone nichelato con filettatura maschio ISO 228 G a battuta piana (A) e filettatura maschio conica EN 10226 R (B)**

*Nickel plated brass M/M nipples with ISO 228 G male thread with plane end (A) and EN 10226 R male taper thread (B)*

Codice Code	DN	Fil. connessione Connection thread		Pz./conf. Pcs./pack	CHF/confez. CHF/pack	CHF/Pz. CHF/Pcs	Conf./box Packs/box
		A	B				
A03-0010-00781	12	G 1/2"	R 1/2"	10	<b>40,50</b>	4,05	-
A03-0010-00782	15	G 3/4"	R 3/4"	10	<b>54,20</b>	5,42	-
A03-0005-00783	20	G 1"	R 1"	5	<b>63,70</b>	12,74	-
A03-0005-00784	25	G 1" 1/4	R 1" 1/4	5	<b>122,10</b>	24,43	-



**Nipplo M/M in ottone con filettatura maschio ISO 228 G a battuta piana (A) e filettatura maschio conica EN 10226 R (B)**

*Brass M/M nipples with double ISO 228 G male thread with plane (A) end and EN 10226 R male taper thread (B)*

Codice Code	DN	Fil. connessione Connection thread		Pz./conf. Pcs./pack	CHF/confez. CHF/pack	CHF/Pz. CHF/Pcs	Conf./box Packs/box
		A	B				
A03-0010-00785	12	G 1/2"	R 1/2"	10	<b>39,90</b>	3,99	-
A03-0010-00786	15	G 3/4"	R 3/4"	10	<b>52,10</b>	5,21	-
A03-0005-00787	20	G 1"	R 1"	5	<b>62,70</b>	12,54	-
A03-0005-00788	25	G 1" 1/4	R 1" 1/4	5	<b>176,60</b>	35,33	-



**Nipplo M/F in ottone nichelato con filettatura maschio ISO 228 G a battuta piana (A) e filettatura femmina EN 10226 Rp (B)**

*Nickel plated brass M/F nipples with ISO 228 G male thread with plane end (A) and EN 10226 Rp female thread (B)*

Codice Code	DN	Fil. connessione Connection thread		Pz./conf. Pcs./pack	CHF/confez. CHF/pack	CHF/Pz. CHF/Pcs	Conf./box Packs/box
		A	B				
A03-0010-00789	12	G 1/2"	Rp 1/2"	10	<b>47,80</b>	4,78	-
A03-0010-00790	15	G 3/4"	Rp 3/4"	10	<b>85,00</b>	8,50	-
A03-0005-00791	20	G 1"	Rp 1"	5	<b>63,60</b>	12,72	-
A03-0005-00792	25	G 1" 1/4	Rp 1" 1/4	5	<b>97,40</b>	19,48	-



**Nipplo M/F in ottone con filettatura maschio ISO 228 G a battuta piana (A) e filettatura femmina EN 10226 Rp (B)**

*Brass M/F nipples with ISO 228 G male thread with plane end (A) and EN 10226 Rp female thread (B)*

Codice Code	DN	Fil. connessione Connection thread		Pz./conf. Pcs./pack	CHF/confez. CHF/pack	CHF/Pz. CHF/Pcs	Conf./box Packs/box
		A	B				
A03-0010-00793	12	G 1/2"	Rp 1/2"	10	<b>46,60</b>	4,66	-
A03-0010-00794	15	G 3/4"	Rp 3/4"	10	<b>80,30</b>	8,03	-
A03-0005-00795	20	G 1"	Rp 1"	5	<b>50,80</b>	10,17	-
A03-0005-00796	25	G 1" 1/4	Rp 1" 1/4	5	<b>93,20</b>	18,63	-

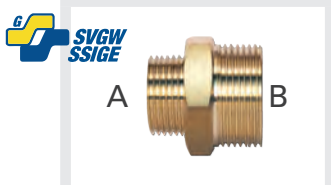

**Nipplo ridotti M/M in ottone con doppia filettatura maschio ISO 228 G a battuta piana (A-B)**

*Brass M/M reduced nipples with double ISO 228 G male thread with plane end (A-B)*

Codice Code	DN	Fil. connessione Connection thread		Pz./conf. Pcs./pack	CHF/confez. CHF/pack	CHF/Pz. CHF/Pcs	Conf./box Packs/box
		A	B				
A03-0010-02534	12-15	G 1/2"	G 3/4"	10	<b>51,40</b>	5,14	-
A03-0005-02535	15-20	G 3/4"	G 1"	5	<b>47,40</b>	9,48	-
A03-0005-04567	20-25	G 1"	G 1" 1/4	5	<b>124,80</b>	24,96	-

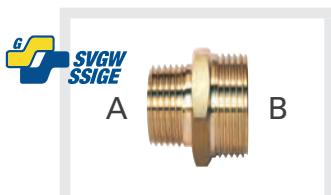

**Nipplo ridotti M/M in ottone con filettatura maschio ISO 228 G a battuta piana (B) e filettatura maschio conica EN 10226 R (A)**

*Brass M/M reduced nipples with ISO 228 G male thread with plane end (B) and EN 10226 R male taper thread (A)*

Codice Code	DN	Fil. connessione Connection thread		Pz./conf. Pcs./pack	CHF/confez. CHF/pack	CHF/Pz. CHF/Pcs	Conf./box Packs/box
		A	B				
A03-0010-00797	15	R 1/2"	G 3/4"	10	<b>62,90</b>	6,29	-
A03-0005-00798	20	R 3/4"	G 1"	5	<b>55,00</b>	10,99	-
A03-0005-00799	25	R 1"	G 1" 1/4	5	<b>92,70</b>	18,54	-



**Nipplo ridotti M/F in ottone con filettatura maschio ISO 228 G a battuta piana (A) e filettatura femmina EN 10226 Rp (B)**

*Brass M/F reduced nipples with ISO 228 G male thread with plane end (A) and EN 10226 Rp female thread (B)*

Codice Code	DN	Fil. connessione Connection thread		Pz./conf. Pcs./pack	CHF/confez. CHF/pack	CHF/Pz. CHF/Pcs	Conf./box Packs/box
		A	B				
A03-0010-04381	12	G 1/2"	Rp 3/4"	10	<b>86,60</b>	8,66	-
A03-0005-04566	15	G 3/4"	Rp 1"	5	<b>50,80</b>	10,17	-
A03-0005-04568	20	G 1"	Rp 1" 1/4	5	<b>106,70</b>	21,34	-





**Nipplo ridotti M/F in ottone con filettatura maschio ISO 228 G a battuta piana (A) e filettatura femmina EN 10226 Rp (B)**

*Brass M/F reduced nipples with ISO 228 G male thread with plane end (A) and EN 10226 Rp female thread (B)*

Codice Code	DN	Fil. connessione Connection thread		Pz./conf. Pcs./pack	CHF/confez. CHF/pack	CHF/Pz. CHF/Pcs	Conf./box Packs/box
		A	B				
A03-0010-00800	15	G 3/4"	Rp 1/2"	10	<b>52,20</b>	5,22	-
A03-0005-00801	20	G 1"	Rp 3/4"	5	<b>34,40</b>	6,88	-
A03-0005-00802	25	G 1" 1/4	Rp 1"	5	<b>77,60</b>	15,53	-

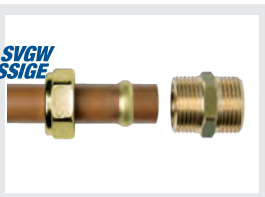

**Raccordi M/M in ottone per collegamento tra tubi CSST flangiati e terminali in rame**

*Brass M/M fittings for connection between flanged PLT-CSST tubes and copper tubes ends*

Codice Code	DN	Fil. connessione Connection thread	De tubo rame De copper tube	Pz./conf. Pcs./pack	CHF/confez. CHF/pack	CHF/Pz. CHF/Pcs	Conf./box Packs/box
A03-0001-01580	12	G 1/2"	14	1	<b>7,40</b>	7,40	-
A03-0001-01581	12	G 1/2"	15	1	<b>12,20</b>	12,20	-
A03-0001-01582	12	G 1/2"	18	1	<b>9,90</b>	9,90	-
A03-0001-01583	15	G 3/4"	18	1	<b>17,30</b>	17,30	-
A03-0001-01584	15	G 3/4"	22	1	<b>12,90</b>	12,90	-
A03-0001-01585	20	G 1"	22	1	<b>22,40</b>	22,40	-
A03-0001-01586	20	G 1"	28	1	<b>24,70</b>	24,70	-
A03-0001-01587	25	G 1" 1/4	28	1	<b>26,90</b>	26,90	-

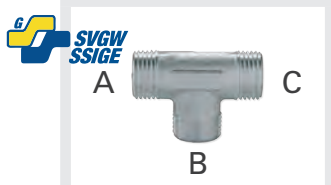

Raccordi TEE M/M/M in ottone nichelato con filettatura maschio ISO 228 G a battuta piana (A-B-C)

*Nickel plated brass M/M/M TEE with ISO 228 G male threads (A-B-C)*

Codice Code	DN	Fil. connessione Connection thread			Pz./conf. Pcs./pack	CHF/confez. CHF/pack	CHF/Pz. CHF/Pcs	Conf./box Packs/box
		A	B	C				
A03-0001-00807	12-12-12	G 1/2"	G 1/2"	G 1/2"	1	<b>11,50</b>	11,50	-
A03-0001-00806	12-12-15	G 1/2"	G 1/2"	G 3/4"	1	<b>10,60</b>	10,60	-
A03-0001-00805	12-15-15	G 1/2"	G 3/4"	G 3/4"	1	<b>11,70</b>	11,70	-
A03-0001-00804	15-12-15	G 3/4"	G 1/2"	G 3/4"	1	<b>12,90</b>	12,90	-
A03-0001-00803	15-15-15	G 3/4"	G 3/4"	G 3/4"	1	<b>13,70</b>	13,70	-
A03-0001-01560	20-20-20	G 1"	G 1"	G 1"	1	<b>27,30</b>	27,30	-
A03-0001-01561	25-25-25	G 1" 1/4	G 1" 1/4	G 1" 1/4	1	<b>45,00</b>	45,00	-

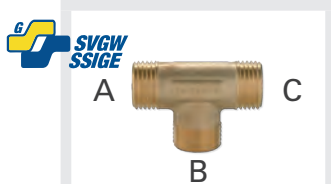

Raccordi TEE M/M/M in ottone con filettatura maschio ISO 228 G a battuta piana (A-B-C)

*Brass M/M/M TEE with ISO 228 G male threads (A-B-C)*

Codice Code	DN	Fil. connessione Connection thread			Pz./conf. Pcs./pack	CHF/confez. CHF/pack	CHF/Pz. CHF/Pcs	Conf./box Packs/box
		A	B	C				
A03-0001-01602	12-12-12	G 1/2"	G 1/2"	G 1/2"	1	<b>11,50</b>	11,50	-
A03-0001-01601	12-12-15	G 1/2"	G 1/2"	G 3/4"	1	<b>10,60</b>	10,60	-
A03-0001-01600	12-15-15	G 1/2"	G 3/4"	G 3/4"	1	<b>11,50</b>	11,50	-
A03-0001-01599	15-12-15	G 3/4"	G 1/2"	G 3/4"	1	<b>12,70</b>	12,70	-
A03-0001-01598	15-15-15	G 3/4"	G 3/4"	G 3/4"	1	<b>13,60</b>	13,60	-
A03-0001-01603	20-20-20	G 1"	G 1"	G 1"	1	<b>27,10</b>	27,10	-
A03-0001-01604	25-25-25	G 1" 1/4	G 1" 1/4	G 1" 1/4	1	<b>44,70</b>	44,70	-



Collettori lineari a due vie in ottone nichelato con filettatura maschio ISO 228 G a battuta piana (B)

*Nickel plated brass two ways linear manifolds with ISO 228 G male threads*

Codice Code	DN	Fil. connessione Connection thread			Pz./conf. Pcs./pack	CHF/confez. CHF/pack	CHF/Pz. CHF/Pcs	Conf./box Packs/box
		A	B	C				
A03-0001-00808	12	G 3/4"	G 1/2"	R 3/4"	1	<b>14,00</b>	14,00	-



Collettori lineari a tre vie in ottone nichelato con filettatura maschio ISO 228 G a battuta piana (B)

*Nickel plated brass three ways linear manifolds with ISO 228 G male threads*

Codice Code	DN	Fil. connessione Connection thread			Pz./conf. Pcs./pack	CHF/confez. CHF/pack	CHF/Pz. CHF/Pcs	Conf./box Packs/box
		A	B	C				
A03-0001-00809	12	G 3/4"	G 1/2"	R 3/4"	1	<b>18,60</b>	18,60	-



Gomito 90° M/F in ottone nichelato con filettatura maschio ISO 228 G a battuta piana (A) e filettatura femmina ISO 228 G (B)

*Nickel plated brass 90° M/F elbows with a ISO 228 G male thread with plane end (A) and a ISO 228 G female thread (B)*

Codice Code	DN	Fil. connessione Connection thread		Pz./conf. Pcs./pack	CHF/confez. CHF/pack	CHF/Pz. CHF/Pcs	Conf./box Packs/box
		A	B				
A03-0001-01921	12	G 1/2"	G 1/2"	1	<b>7,90</b>	7,90	-



Gomito 90° M/M in ottone nichelato con filettatura maschio ISO 228 G a battuta piana (A) e filettatura maschio ISO 228 G con sede per tubo rame De 14 (B)

*Nickel plated brass 90° elbows with ISO 228 G male thread with plane end (A) and ISO 228 G male thread with seat for De14 copper tube (B)*

Codice Code	DN	Fil. connessione Connection thread		Pz./conf. Pcs./pack	CHF/confez. CHF/pack	CHF/Pz. CHF/Pcs	Conf./box Packs/box
		A	B				
A03-0001-01922	12	G 1/2"	G 1/2"	1	<b>6,90</b>	6,90	-



Gomito a fissaggio M/F in ottone nichelato con filettatura maschio ISO 228 G a battuta piana (B) e filettatura femmina ISO 228 G (A)

*Nickel plated brass M/F wall elbows with ISO 228 G male thread with plane end (B) and ISO 228 G female thread (A)*

Codice Code	DN	Fil. connessione Connection thread		Pz./conf. Pcs./pack	CHF/confez. CHF/pack	CHF/Pz. CHF/Pcs	Conf./box Packs/box
		A	B				
A03-0001-00812	12	G 1/2"	G 1/2"	1	<b>7,00</b>	7,00	-
A03-0001-00813	15	G 3/4"	G 3/4"	1	<b>11,00</b>	11,00	-
A03-0001-00814	15	G 1/2"	G 3/4"	1	<b>10,00</b>	10,00	-

## Guarnizioni per sistema a cartellare

Flanging gaskets for flanging system

Da DN 12 a DN 25



**KLINGERSIL C4324: Guarnizioni piane a base di fibre sintetiche idonee per impianti gas**  
*KLINGERSIL C4324: synthetic fibers plane gaskets for gas systems*

Codice Code	DN	Per dado For nut	Per tubo - For tube		Pz./conf. Pcs./pack	CHF/confez. CHF/pack	CHF/Pz. CHF/Pcs	Conf./box Packs/box
			AISI 304	AISI 316L				
A04-0010-00836	10	3/8"	●		10	<b>2,07</b>	0,21	-
A04-0010-00837	12	1/2"	●	●	10	<b>2,99</b>	0,30	-
A04-0010-00838	15	3/4"	●	●	10	<b>4,14</b>	0,41	-
A04-0010-00839	20	1"	●	●	10	<b>6,10</b>	0,61	-
A04-0010-00840	25	1" 1/4	●	●	10	<b>10,24</b>	1,02	-



**AFM34: Guarnizioni piane a base di fibre aramidiche idonee per impianti gas**  
*AFM34: Aramidic fibre plane gaskets for gas systems*

Codice Code	DN	Per dado For nut	Per tubo - For tube		Pz./conf. Pcs./pack	CHF/confez. CHF/pack	CHF/Pz. CHF/Pcs	Conf./box Packs/box
			AISI 304	AISI 316L				
A04-0010-00843	10	3/8"	●		10	<b>7,36</b>	0,74	-
A04-0010-00844	12	1/2"	●	●	10	<b>5,64</b>	0,56	-
A04-0010-00845	15	3/4"	●	●	10	<b>8,51</b>	0,85	-
A04-0010-00846	20	1"	●	●	10	<b>12,19</b>	1,22	-
A04-0010-00847	25	1" 1/4	●	●	10	<b>21,85</b>	2,19	-



**NBR: Guarnizioni piane in NBR a norma EN 682 per gas**

*NBR: NBR plane gaskets conform to EN 682 standard for gas*

Codice Code	DN	Per dado For nut	Pz./conf. Pcs./pack	CHF/confez. CHF/pack	CHF/Pz. CHF/Pcs	Conf./box Packs/box
A04-0010-01923	12	1/2"	10	<b>4,90</b>	0,49	-
A04-0010-01924	15	3/4"	10	<b>5,10</b>	0,51	-
A04-0010-01925	20	1"	10	<b>6,90</b>	0,69	-
A04-0010-01926	25	1" 1/4	10	<b>9,90</b>	0,99	-



**NBR: Guarnizioni piane ridotte in NBR a norma EN 682 per gas**

*NBR: NBR reduced plane gaskets conform to EN 682 standard for gas*

Codice Code	DN	Per dado For nut	Pz./conf. Pcs./pack	CHF/confez. CHF/pack	CHF/Pz. CHF/Pcs	Conf./box Packs/box
A04-0010-01962	12	3/4"	10	<b>10,20</b>	1,02	-
A04-0010-01964	15	1"	10	<b>12,20</b>	1,22	-
A04-0010-01963	20	1" 1/4	10	<b>15,90</b>	1,59	-

## Sistema a cartellare XL

### XL flanging system



## Raccordi per sistema a cartellare XL

### Fittings for XL flanging system

Da DN 32 a DN 50



#### Dadi in ottone a sede speciale con filettatura femmina ISO 228 G

Brass nuts with special seat and ISO 228 G female thread without gaskets

Codice Code	DN	Filettatura ISO 228 ISO 228 thread	Pz./conf. Pcs./pack	CHF/confez. CHF/pack	CHF/Pz. CHF/Pcs	Conf./box Packs/box
A02-0001-06970	32	G 1" 1/2	1	20,20	20,20	-
A02-0001-06971	40	G 2"	1	25,10	25,10	-
A02-0001-06972	50	G 2" 1/2	1	32,10	32,10	-

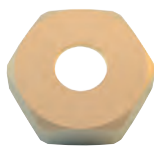

#### Dadi ridotti in ottone a sede speciale con filettatura femmina ISO 228 G

Reduced brass nuts with special seat and ISO 228 G female thread without gaskets

Codice Code	DN	Pz./conf. Pcs./pack	CHF/confez. CHF/pack	CHF/Pz. CHF/Pcs	Conf./box Packs/box
A02-0001-06989	32-12	1	22,20	22,20	-
A02-0001-06982	32-15	1	22,20	22,20	-
A02-0001-06983	32-20	1	22,20	22,20	-
A02-0001-06984	32-25	1	22,20	22,20	-
A02-0001-06978	40-15	1	26,90	26,90	-
A02-0001-06979	40-20	1	26,90	26,90	-
A02-0001-06980	40-25	1	28,90	28,90	-
A02-0001-06981	40-32	1	28,90	28,90	-
A02-0001-06973	50-15	1	36,00	36,00	-
A02-0001-06974	50-20	1	36,00	36,00	-
A02-0001-06975	50-25	1	36,00	36,00	-
A02-0001-06976	50-32	1	35,80	35,80	-
A02-0001-06977	50-40	1	35,80	35,80	-



**Adattatori in ottone per dadi ridotti a battuta piana con o-ring in HNBR**  
*Brass adapters for reduced nuts with o-rings in HNBR*

Codice Code	DN	Pz./conf. Pcs./pack	CHF/confez. CHF/pack	CHF/Pz. CHF/Pcs	Conf./box Packs/box
A03-0001-07053	32-12	1	19,20	19,20	-
A03-0001-07018	32-15	1	19,20	19,20	-
A03-0001-07019	32-20	1	19,20	19,20	-
A03-0001-07020	32-25	1	19,20	19,20	-
A03-0001-07021	40-15	1	25,60	25,60	-
A03-0001-07022	40-20	1	25,60	25,60	-
A03-0001-07023	40-25	1	24,50	24,50	-
A03-0001-07024	40-32	1	32,00	32,00	-
A03-0001-07025	50-15	1	33,20	33,20	-
A03-0001-07026	50-20	1	33,20	33,20	-
A03-0001-07027	50-25	1	33,20	33,20	-
A03-0001-07028	50-32	1	31,20	31,20	-
A03-0001-07029	50-40	1	31,20	31,20	-



**Raccordi giunto maschio in ottone con filettatura maschio EN 10226**  
*Brass male joint with EN 10226 male thread*

Codice Code	DN	Filettatura EN 10226 EN 10226 thread	Pz./conf. Pcs./pack	CHF/confez. CHF/pack	CHF/Pz. CHF/Pcs	Conf./box Packs/box
A03-0001-06994	32	R 1" 1/4	1	29,30	29,30	-
A03-0001-06995	40	R 1" 1/2	1	43,20	43,20	-
A03-0001-06996	50	R 2"	1	60,50	60,50	-



**Raccordi giunto femmina in ottone con filettatura femmina EN 10226**  
*Brass female joint with EN 10226 female thread*

Codice Code	DN	Filettatura EN 10226 EN 10226 thread	Pz./conf. Pcs./pack	CHF/confez. CHF/pack	CHF/Pz. CHF/Pcs	Conf./box Packs/box
A03-0001-06991	32	Rp 1" 1/4	1	25,20	25,20	-
A03-0001-06992	40	Rp 1" 1/2	1	36,10	36,10	-
A03-0001-06993	50	Rp 2"	1	55,40	55,40	-



**Nippli M/M in ottone con doppia filettatura maschio ISO 228 G a battuta piana**  
*Brass M/M nipples with double ISO 228 G male thread with plane end*

Codice Code	DN	Pz./conf. Pcs./pack	CHF/confez. CHF/pack	CHF/Pz. CHF/Pcs	Conf./box Packs/box
A03-0001-06997	32-32	1	32,40	32,40	-
A03-0001-06998	40-40	1	46,50	46,50	-
A03-0001-06999	50-50	1	69,50	69,50	-



**TEE M/M/M in ottone con filettatura maschio ISO 228 G a battuta piana**  
*Brass M/M/M TEE joint with ISO 228 G male threads*

Codice Code	DN	Pz./conf. Pcs./pack	CHF/confez. CHF/pack	CHF/Pz. CHF/Pcs	Conf./box Packs/box
A03-0001-07030	32-32-32	1	50,70	50,70	-
A03-0001-07031	40-40-40	1	78,70	78,70	-



**Flange in acciaio inox per tubazioni corrugate formabili CSST**  
*Stainless steel flanges for PLT-CSST pliable corrugated tubes*

Codice Code	DN	Fil. connessione Connection thread	Pz./conf. Pcs./pack	CHF/confez. CHF/pack	CHF/Pz. CHF/Pcs	Conf./box Packs/box
A03-0001-08594	32	1" 1/2	1	180,60	180,60	-
A03-0001-08595	40	2"	1	193,20	193,20	-
A03-0001-08596	50	2" 1/2	1	219,90	219,90	-



## Guarnizioni per sistema a cartellare XL

Flanging gaskets for XL flanging system

Da DN 32 a DN 50



**NBR: guarnizioni piane in NBR a norma EN 682 per gas**  
*NBR: NBR plane gaskets conform to EN 682 standard for gas*

Codice Code	DN	Per dado For nut	Pz./conf. Pcs./pack	CHF/confez. CHF/pack	CHF/Pz. CHF/Pcs	Conf./box Packs/box
A04-0001-07057	32	1" 1/2	1	5,60	5,60	-
A04-0001-07058	40	2"	1	6,20	6,20	-
A04-0001-07059	50	2" 1/2	1	7,10	7,10	-



**NBR: guarnizioni piane in NBR a norma EN 682 per gas**  
*NBR: NBR plane gaskets conform to EN 682 standard for gas*

Codice Code	DN	Per dado For nut	Pz./conf. Pcs./pack	CHF/confez. CHF/pack	CHF/Pz. CHF/Pcs	Conf./box Packs/box
A04-0001-07073	32/12	A02-0001-06989	1	9,00	9,00	-
A04-0001-07074	32/15	A02-0001-06982	1	9,00	9,00	-
A04-0001-07075	32/20	A02-0001-06983	1	9,00	9,00	-
A04-0001-07076	32/25	A02-0001-06984	1	9,00	9,00	-
A04-0001-07077	40/15	A02-0001-06978	1	9,50	9,50	-
A04-0001-07078	40/20	A02-0001-06979	1	9,50	9,50	-
A04-0001-07079	40/25	A02-0001-06980	1	9,50	9,50	-
A04-0001-07080	40/32	A02-0001-06981	1	9,50	9,50	-
A04-0001-07081	50/15	A02-0001-06973	1	10,20	10,20	-
A04-0001-07082	50/20	A02-0001-06974	1	10,20	10,20	-
A04-0001-07083	50/25	A02-0001-06975	1	10,20	10,20	-
A04-0001-07084	50/32	A02-0001-06976	1	10,20	10,20	-
A04-0001-07085	50/40	A02-0001-06977	1	10,20	10,20	-



**NBR: guarnizioni piane per flange DN 32, 40, 50 a norma EN 682 per gas**

*NBR: plane gaskets for flange DN 32, 40, 50 conform to EN 682 standard for gas*

Codice Code	DN	Per dado For nut	Pz./conf. Pcs./pack	CHF/confez. CHF/pack	CHF/Pz. CHF/Pcs	Conf./box Packs/box
A04-0001-08732	32	1" 1/2	1	<b>3,70</b>	3,70	-
A04-0001-08733	40	2"	1	<b>4,60</b>	4,60	-
A04-0001-08734	50	2" 1/2	1	<b>5,50</b>	5,50	-

## Sistema a pressare Press-fitting system



## Raccordi per sistema a pressare Fittings for press-fitting system

Da DN 12 a DN 25



Raccordi a pressare filettati maschio in ottone con guarnizioni in HNBR a norma EN 682 idonee al trasporto gas, per il collegamento tra tubi CSST e terminali filettati femmina EN 10226 R

*Male brass press-fittings with HNBR gasket conform to EN 682 for gas installations, for connection between PLT-CSST tubes and female thread ends EN 10226 R*

Codice Code	DN	Fil. connessione Connection thread	Pz./conf. Pcs./pack	CHF/confez. CHF/pack	CHF/Pz. CHF/Pcs	Conf./box Packs/box
A03-0020-06624	12	R 1/2"	20	192,70	9,64	-
A03-0010-06616	15	R 3/4"	10	109,00	10,90	-
A03-0005-06332	20	R 1"	5	79,90	15,99	-
A03-0005-07394	25	R 1" 1/4	5	137,90	27,58	-



Raccordi a pressare filettati femmina in ottone con guarnizioni in HNBR a norma EN 682 idonee al trasporto gas, per il collegamento tra tubi CSST e terminali filettati maschio EN 10226 Rp

*Female brass press-fittings with HNBR gasket conform to EN 682 for gas installations, for connection between PLT-CSST tubes and male thread ends EN 10226 R*

Codice Code	DN	Fil. connessione Connection thread	Pz./conf. Pcs./pack	CHF/confez. CHF/pack	CHF/Pz. CHF/Pcs	Conf./box Packs/box
A03-0020-06623	12	Rp 1/2"	20	201,80	10,09	-
A03-0010-06615	15	Rp 3/4"	10	113,50	11,35	-
A03-0005-06336	20	Rp 1"	5	83,50	16,70	-
A03-0005-07395	25	Rp 1" 1/4	5	141,30	28,27	-



Raccordi a pressare con girello in ottone con guarnizioni in HNBR a norma EN 682 idonee al trasporto di gas, per il collegamento tra tubi CSST e terminali filettati maschio a sede piana EN 10226 G

*Brass press-fittings with swivel end with HNBR gasket conform to EN 682 for gas installations, for connection between PLT-CSST tubes and male thread ends EN 10226 G*

Codice Code	DN	Fil. connessione Connection thread	Pz./conf. Pcs./pack	CHF/confez. CHF/pack	CHF/Pz. CHF/Pcs	Conf./box Packs/box
A03-0020-06625	12	G 1/2"	20	187,90	9,40	-
A03-0010-06610	12	G 3/4"	10	116,20	11,62	-
A03-0010-06614	15	G 3/4"	10	136,90	13,69	-
A03-0005-06638	15	G 1"	5	83,50	16,70	-
A03-0005-06338	20	G 1"	5	102,40	20,47	-



Manicotti a pressare in ottone con guarnizioni in HNBR a norma EN 682 idonee al trasporto di gas, per il collegamento tra tubi CSST dello stesso diametro

*Nipple/coupling brass press-fittings HNBR gasket conform to EN 682 for gas installations, for connection between PLT-CSST tubes of same diameter*

Codice Code	DN	Fil. connessione Connection thread	Pz./conf. Pcs./pack	CHF/confez. CHF/pack	CHF/Pz. CHF/Pcs	Conf./box Packs/box
A03-0020-06626	12	-	20	231,00	11,55	-
A03-0010-06617	15	-	10	152,70	15,27	-
A03-0005-06344	20	-	5	106,80	21,37	-
A03-0005-07396	25	-	5	172,70	34,55	-



Manicotti ridotti a pressare in ottone con guarnizione in HNBR a norma EN 682 idonee al trasporto di gas, per il collegamento tra tubi CSST di diametri differenti

*Reduced nipple/coupling brass press-fittings with HNBR gasket conform to EN 682 for gas installations, for connection between PLT-CSST tubes of different diameters*

Codice Code	DN	Fil. connessione Connection thread	Pz./conf. Pcs./pack	CHF/confez. CHF/pack	CHF/Pz. CHF/Pcs	Conf./box Packs/box
A03-0010-06618	15-12	-	10	143,40	14,34	-
A03-0005-06505	20-15	-	5	107,20	21,44	-
A03-0005-07398	25-15	-	5	160,40	32,09	-
A03-0005-07399	25-20	-	5	165,90	33,19	-



**Raccordi TEE a pressare in ottone con guarnizione in HNBR a norma EN 682 idonee al trasporto di gas, per il collegamento tra tubi CSST dello stesso diametro**

*Brass TEE press-fittings HNBR gasket conform to EN 682 for gas installations, for connection between PLT-CSST tubes of same diameter*

Codice Code	DN	Fil. connessione Connection thread	Pz./conf. Pcs./pack	CHF/confez. CHF/pack	CHF/Pz. CHF/Pcs	Conf./box Packs/box
A03-0010-06613	12	-	10	<b>280,90</b>	28,09	-
A03-0005-06358	15	-	5	<b>189,40</b>	37,88	-
A03-0005-06503	20	-	5	<b>195,80</b>	39,17	-
A03-0004-07400	25	-	4	<b>245,50</b>	49,11	-



**Raccordi TEE ridotti a pressare in ottone con guarnizione in HNBR a norma EN 682 idonee al trasporto di gas, per il collegamento tra tubi CSST di diametri differenti**

*Reduced brass TEE press-fittings with HNBR gasket conform to EN 682 for gas installations, for connection between PLT-CSST tubes of different diameters*

Codice Code	DN	Fil. connessione Connection thread	Pz./conf. Pcs./pack	CHF/confez. CHF/pack	CHF/Pz. CHF/Pcs	Conf./box Packs/box
A03-0005-06360	15-12-15	-	5	<b>187,20</b>	37,44	-
A03-0005-06509	20-12-20	-	5	<b>190,60</b>	38,11	-
A03-0005-06511	20-15-20	-	5	<b>193,50</b>	38,71	-
A03-0004-07402	25-15-25	-	4	<b>239,40</b>	47,89	-
A03-0004-07403	25-20-25	-	4	<b>245,40</b>	49,08	-



**Raccordi a gomito 90° a pressare con girello in ottone con guarnizione in HNBR a norma EN 682 idonee al trasporto di gas, per il collegamento tra tubi CSST e terminali filettati maschio a sede piana ISO 228 G**

*Brass 90° elbow press-fittings with swivel nut with HNBR gasket conform to EN 682 for gas installations, for connection between PLT-CSST tubes and male thread ends ISO 228 G*

Codice Code	DN	Fil. connessione Connection thread	Pz./conf. Pcs./pack	CHF/confez. CHF/pack	CHF/Pz. CHF/Pcs	Conf./box Packs/box
A03-0010-06612	12	G 1/2"	10	<b>111,80</b>	11,18	-



Raccordi a gomito 90° filettati femmina a pressare in ottone con guarnizione in HNBR a norma EN 682 idonee al trasporto di gas, per il collegamento tra tubi CSST e terminali filettati maschio EN 10226 Rp

*Brass 90° elbow press-fittings female thread with HNBR gasket conform to EN 682 for gas installations, for connection between PLT-CSST tubes and male thread ends EN 10226 Rp*

Codice Code	DN	Fil. connessione Connection thread	Pz./conf. Pcs./pack	CHF/confez. CHF/pack	CHF/Pz. CHF/Pcs	Conf./box Packs/box
A03-0010-06611	12	Rp 1/2"	10	<b>106,30</b>	10,63	-



Raccordi a gomito 90° a pressare in ottone con staffa di fissaggio in ottone e guarnizione in HNBR a norma EN 682 idonee al trasporto di gas, per il collegamento tra tubi CSST e terminali filettati maschio EN 10226 Rp

*Brass 90° elbow press-fittings with fixing bracket and HNBR gasket conform to EN 682 for gas installations, for connection between PLT-CSST tubes and male thread ends EN 10226 Rp*

Codice Code	DN	Fil. connessione Connection thread	Pz./conf. Pcs./pack	CHF/confez. CHF/pack	CHF/Pz. CHF/Pcs	Conf./box Packs/box
A03-0010-07391	12	Rp 1/2"	10	<b>146,20</b>	14,62	-
A03-0005-07392	15	Rp 1/2"	5	<b>90,40</b>	18,08	-
A03-0005-07393	15	Rp 3/4"	5	<b>109,40</b>	21,87	-

## Sistema a doppio o-ring

Double o-ring system



## Raccordi per sistema a doppio o-ring

Fittings for double o-ring system

Da DN 12 a DN 50



Raccordi filettati M in ottone ad innesto rapido con doppio o-ring in NBR a norma EN 682 per gas, con filettatura maschio conica EN 10226 R o parallela ISO 228 G, per il collegamento tra tubi CSST e terminali filettati femmina

*Brass M/M fast coupling fittings with taper EN 10226 R or parallel ISO 228 G thread with o-rings in NBR conform to EN 682 standard for gas for connection between PLT-CSST tubes and female thread ends*

SVGW SSGE	Codice Code	DN	Fil. connessione Connection thread	Pz./conf. Pcs./pack	CHF/confez. CHF/pack	CHF/Pz. CHF/Pcs	Conf./box Packs/box
	A03-0001-02986	12	R 1/2"	1	<b>7,20</b>	7,20	-
	A03-0001-01507	12	G 1/2"	1	<b>7,20</b>	7,20	-
	A03-0001-02987	15	R 3/4"	1	<b>8,10</b>	8,10	-
	A03-0001-01497	15	G 3/4"	1	<b>8,10</b>	8,10	-
	A03-0001-02988	20	R 1"	1	<b>16,30</b>	16,30	-
	A03-0001-01511	20	G 1"	1	<b>16,30</b>	16,30	-
	A03-0001-02989	25	R 1" 1/4	1	<b>25,40</b>	25,40	-
	A03-0001-01515	25	G 1" 1/4	1	<b>25,40</b>	25,40	-
	A03-0001-04249	32	G 1" 1/2	1	<b>42,60</b>	42,60	-
	A03-0001-04252	40	G 2"	1	<b>70,80</b>	70,80	-
	A03-0001-04261	50	G 2" 1/2	1	<b>106,50</b>	106,50	-



Raccordi filettati femmina in ottone ad innesto rapido con doppio o-ring in NBR a norma EN 682 per gas, con filettatura femmina ISO 228 G, per il collegamento tra tubi CSST e terminali filettati maschio

*Brass M/F fast coupling fittings with o-rings in NBR conform to EN 682 standard for gas for connection between PLT-CSST tubes and male thread ends*

SVGW SSGE	Codice Code	DN	Fil. connessione Connection thread	Pz./conf. Pcs./pack	CHF/confez. CHF/pack	CHF/Pz. CHF/Pcs	Conf./box Packs/box
	A03-0001-01508	12	G 1/2"	1	8,60	8,60	-
	A03-0001-01503	15	G 3/4"	1	9,10	9,10	-
	A03-0001-01512	20	G 1"	1	16,60	16,60	-
	A03-0001-01516	25	G 1" 1/4	1	22,70	22,70	-
	A03-0001-04250	32	G 1" 1/2	1	38,10	38,10	-
	A03-0001-04253	40	G 2"	1	63,50	63,50	-
	A03-0001-04262	50	G 2" 1/2	1	95,60	95,60	-



Raccordi in ottone ad innesto rapido con doppio o-ring in NBR a norma EN 682 per gas, per il collegamento tra tubi CSST dello stesso diametro

*Brass fast coupling fittings with o-rings in NBR conform to EN 682 standard for gas for connection between PLT-CSST tubes with same diameter*

SVGW SSGE	Codice Code	DN	Pz./conf. Pcs./pack	CHF/confez. CHF/pack	CHF/Pz. CHF/Pcs	Conf./box Packs/box
	A03-0001-01862	12	1	10,40	10,40	-
	A03-0001-01864	15	1	11,00	11,00	-
	A03-0001-01866	20	1	18,60	18,60	-
	A03-0001-01868	25	1	34,70	34,70	-
	A03-0001-04251	32	1	58,10	58,10	-
	A03-0001-04254	40	1	96,80	96,80	-
	A03-0001-04263	50	1	145,10	145,10	-





Raccordi in ottone ad innesto rapido con doppio o-ring in NBR a norma EN 682 per gas, per il collegamento tra tubi CSST e terminali in rame

*Brass fast coupling fittings with o-rings in NBR conform to EN 682 standard for gas for connection between PLT-CSST tubes and copper tubes ends*

Codice Code	DN	De tubo rame De copper tube	Pz./conf. Pcs./pack	CHF/confez. CHF/pack	CHF/Pz. CHF/Pcs	Conf./box Packs/box
A03-0001-01722	12	14	1	<b>10,70</b>	10,70	-
A03-0001-01723	12	15	1	<b>14,00</b>	14,00	-
A03-0001-01724	12	18	1	<b>12,20</b>	12,20	-
A03-0001-01727	15	18	1	<b>12,20</b>	12,20	-
A03-0001-01728	15	22	1	<b>19,40</b>	19,40	-
A03-0001-01731	20	22	1	<b>19,40</b>	19,40	-
A03-0001-01732	20	28	1	<b>35,10</b>	35,10	-
A03-0001-01734	25	28	1	<b>43,10</b>	43,10	-

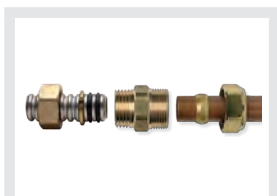

**Raccordi in ottone ad innesto rapido con doppio o-ring in NBR a norma EN 682 per gas, per il collegamento tra tubi CSST e terminali in rame**

*Brass fast coupling fittings with o-rings in NBR conform to EN 682 standard for gas for connection between PLT-CSST tubes and copper tubes ends*

Codice Code	DN	De tubo rame De copper tube	Pz./conf. Pcs./pack	CHF/confez. CHF/pack	CHF/Pz. CHF/Pcs	Conf./box Packs/box
A03-0001-01722	12	14	1	<b>9,30</b>	9,30	-
A03-0001-01723	12	15	1	<b>12,20</b>	12,20	-
A03-0001-01724	12	18	1	<b>10,60</b>	10,60	-
A03-0001-01727	15	18	1	<b>10,60</b>	10,60	-
A03-0001-01728	15	22	1	<b>16,90</b>	16,90	-
A03-0001-01731	20	22	1	<b>16,90</b>	16,90	-
A03-0001-01732	20	28	1	<b>30,50</b>	30,50	-
A03-0001-01734	25	28	1	<b>37,50</b>	37,50	-

## Attrezzature Tools



**Tagliatubi per tubazioni CSST Eurotis da DN 10 a DN 25**  
*PLT-CSST tube cutter from DN 10 to DN 25*

Codice Code	DN		Per tubo - For tube		Applicazione - Application			Pz./conf. Pcs./pack	CHF/confez. CHF/pack	Conf./box Packs/box
	Min	Max	AISI 304	AISI 316L						
A06-0001-05409	10	25	●	●	●	●	●	1	60,60	-



**Tagliatubi per tubazioni CSST Eurotis da DN 15 a DN 60**  
*PLT-CSST tube cutter from DN 15 to DN 60*

Codice Code	DN		Per tubo - For tube		Applicazione - Application			Pz./conf. Pcs./pack	CHF/confez. CHF/pack	Conf./box Packs/box
	Min	Max	AISI 304	AISI 316L						
A06-0001-07500	15	60	●	●	●	●	●	1	251,70	-

## Attrezzature per sistema a cartellare Tools for flanging system

Da DN 10 a DN 50

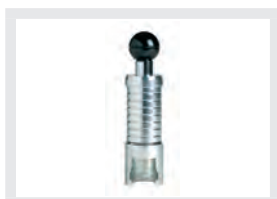

Attrezzo di flangiatura manuale "60 DB" per tubazioni CSST Eurotis  
Manual flanging tool "60 DB" for Eurotis PLT-CSST tubes

Codice Code	DN		Per tubo - For tube		Applicazione - Application			Pz./conf. Pcs./pack	CHF/confez. CHF/pack	Conf./box Packs/box
	Min	Max	AISI 304	AISI 316L						
A06-0001-02395	10	25	●	●	●	●	●	1	127,50	1



## ADAPTOR

Attrezzo di flangiatura "60 DB" per tubazioni CSST Eurotis adattabile ad ogni tipo di macchina pressatrice\* (brevettato) a 32 kN  
Automatic flanging tool adaptable to any type of pressing machine\* (patented) 32 kN

Codice Code	DN		Per tubo - For tube		Applicazione - Application			Pz./conf. Pcs./pack	CHF/confez. CHF/pack	Conf./box Packs/box
	Min	Max	AISI 304	AISI 316L						
A06-0001-05156	10	25	●	●	●	●	●	1	273,00	-

\* Ad eccezione delle macchine pressatrici "mini". Testato sulle principali macchine pressatrici in commercio.  
\* Except for pressing machines "mini". Tested on the main crimping machines on the market.



Dima "60 DB" flangiatura per tubi CSST sia manuale che automatica da DN 10 a DN 25  
"60 DB" template for PLT-CSST tubes, both manual and automatic from DN 10 a DN 25

Codice Code	DN	Per tubo - For tube		Applicazione - Application			Pz./conf. Pcs./pack	CHF/confez. CHF/pack	Conf./box Packs/box
		AISI 304	AISI 316L						
A06-0001-01927	10 12	● ●		● ●			1	36,20	-
A06-0001-02292	12 15	● ●		● ●	● ●		1	36,20	-
A06-0001-00878	12 15		● ●	● ●	● ●	● ●	1	36,20	-
A06-0001-00876	20 25	● ●	● ●	● ●	● ●	● ●	1	36,20	-



## XLADAPTOR

Attrezzo di flangiatura per tubazioni CSST Eurotis adattabile ad ogni tipo di macchina pressatrice\* (brevettato) 32 kN

Automatic flanging tool adaptable to any type of pressing machine\* (patented) 32 kN

Codice Code	DN		Per tubo - For tube		Applicazione - Application			Pz./conf. Pcs./pack	CHF/confez. CHF/pack	Conf./box Packs/box
	Min	Max	AISI 304	AISI 316L						
A06-0001-05464	32	50	●	●	●	●	●	1	510,60	1

\* Ad eccezione delle macchine pressatrici "mini". Testato sulle principali macchine pressatrici in commercio.  
\* Except for pressing machines "mini". Tested on the main crimping machines on the market.



## Dima di flangiatura per tubi CSST

Flanging template "60DB" for PLT-CSST tubes

Codice Code	DN	Per tubo - For tube		Applicazione - Application			Pz./conf. Pcs./pack	Confez. Pack	CHF/confez. CHF/pack	Conf./box Packs/box
		AISI 304	AISI 316L							
A06-0001-05465	32	●	●	●	●	●	1	1	201,60	1
A06-0001-05466	40	●	●	●	●	●			201,60	
A06-0001-05467	50	●	●	●	●	●			201,60	



## REMS - Kit con attrezzo automatico di flangiatura per tubi CSST Eurotis

REMS - Kit with automatic flanging tool for PLT-CSST tubes

Codice Code	N° kit/conf. N° kit/pack	CHF/confez. CHF/pack
A06-0001-04610	1	2.842,20

N° pz. / pcs.	Descrizione - Description
1	Valigetta in metallo / Metal tool case.
1	Attrezzo automatico di flangiatura per tubi CSST. Flanging automatic tool for PLT-CSST tubes.
1	Batteria al litio con caricatore. Lithium battery - with battery charger.
1	Dima "60 DB" DN 10 - DN 12 per tubo CSST in AISI 304. Template "60 DB" for DN 10 - DN 12 AISI 304 PLT-CSST tube.
1	Dima "60DB" DN 15 per tubi CSST in AISI 304 e AISI 316L DN 12 per tubo PLT-CSST in AISI 316L. Template "60 DB" for DN 15 AISI 304 and AISI 316L PLT-CSST tube DN 12 AISI 316L PLT-CSST tube.
1	Dima "60 DB" DN 20 DN 25 per tubo CSST in AISI 304 e AISI 316L. Template "60 DB" for DN 20 DN 25 for AISI 304 and AISI 316L PLT-CSST tube.
1	Manuale d'istruzioni / Instruction leaflet.

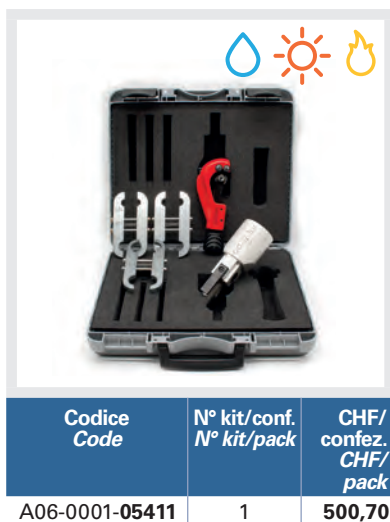

## Kit ADAPTOR ADAPTOR Kit

N° pz. / pcs.	Descrizione - Description
1	Valigetta polipropilene / Polypropylene tool case.
1	ADAPTOR: Attrezzo di flangiatura "60 DB" per tubazioni CSST Eurotis adattabile ad ogni tipo di macchina pressatrice* (brevettato). <i>ADAPTOR - Automatic flanging tool adaptable to any type of pressing machine (patented).</i>
1	Tagliatubo per tubazioni CSST Eurotis da DN 10 a DN 25. <i>PLT-CSST tube cutter from DN 10 to DN 25.</i>
1	Dima di flangiatura "60 DB" per tubazione CSST Eurotis DN 20 e DN 25 in acciaio inossidabile AISI 304 / AISI 316 L (acqua - solare - gas). <i>Template "60 DB" for DN 20 and DN 25 AISI 304 and AISI 316L PLT-CSST tube.</i>
1	Dima di flangiatura "60 DB" per tubazione CSST Eurotis DN 15 in acciaio inossidabile AISI 304 / AISI 316 L (acqua - solare - gas) e DN 12 in acciaio inossidabile AISI 316 L (gas). <i>Template "60 DB" for DN 15 AISI 304 and AISI 316L PLT-CSST tube DN 12 AISI 316L PLT-CSST tube.</i>
1	Dima di flangiatura "60 DB" per tubazione CSST Eurotis DN 10 in acciaio inossidabile AISI 304 (acqua) e DN 12 in acciaio inossidabile AISI 304 (acqua - solare). <i>Template "60 DB" for DN 10 AISI 304 PLT-CSST tube DN 12 AISI 304 PLT-CSST tube.</i>

\* Ad eccezione delle macchine pressatrici "mini". Testato sulle principali macchine pressatrici in commercio.\* Except for pressing machines "mini". Tested on the main crimping machines on the market.

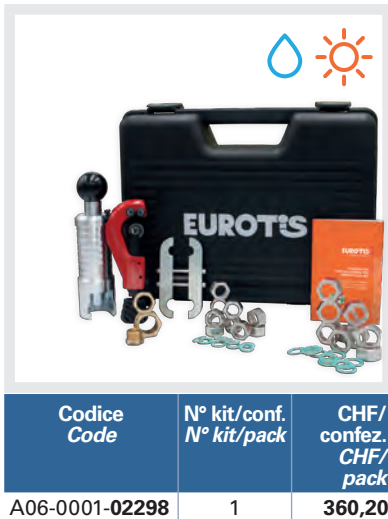

## EUROWATER/EUROSOLAR Kit (Vgkit)

N° pz. pcs.	Descrizione - Description
1	Valigetta polipropilene / Polypropylene tool case.
1	Attrezzo di flangiatura manuale "60 DB" per tubazioni CSST Eurotis. <i>Manual flanging tool "60 DB".</i>
1	Tagliatubo per tubazioni CSST Eurotis da DN 10 a DN 25. <i>PLT-CSST tube cutter from DN 10 to DN 25.</i>
1	Dima di flangiatura "60 DB" per tubazione CSST Eurotis DN 15 in acciaio inossidabile AISI 304 /AISI 316 L (acqua - solare - gas) e DN 12 in acciaio inossidabile AISI 304 (acqua - solare). <i>Template "60 DB" for DN 15 AISI 304 and AISI 316L PLT-CSST tube DN 12 AISI 304 PLT-CSST tube.</i>
20	Dadi DN 12 in ottone nichelato a sede speciale con filettatura femmina G 1/2 e guarnizioni piane KLINGERSIL C4324 idonee al trasporto di acqua potabile e resistenti ad alte temperature operative continue. <i>Nickel plated brass nuts with special seat and ISO 228 G female thread with synthetic fibers KLINGERSIL C4324 plane gaskets suitable for drinking water and resistant to high continuous working temperatures - DN 12 (G 1/2).</i>
20	Dadi DN 15 in ottone nichelato a sede speciale con filettatura femmina G 3/4 e guarnizioni piane KLINGERSIL C4324 idonee al trasporto di acqua potabile e resistenti ad alte temperature operative continue. <i>Nickel plated brass nuts with special seat and ISO 228 G female thread with synthetic fibers KLINGERSIL C4324 plane gaskets suitable for drinking water and resistant to high continuous working temperatures - DN 15 (G 3/4).</i>

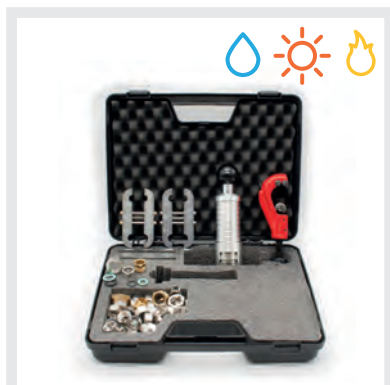

## Plurima Light Kit

Codice Code	N° kit/conf. N° kit/pack	CHF/confez. CHF/pack
A06-0001-03101	1	392,30

N° pz. pcs.	Descrizione - Description
1	Valigetta polipropilene / Polypropylene tool case.
1	Attrezzo di flangiatura manuale "60 DB" per tubazioni CSST Eurotis. <i>Manual flanging tool "60 DB"</i>
1	Tagliatubo per tubazioni CSST Eurotis da DN 10 a DN 25. <i>PLT-CSST tube cutter from DN 10 to DN 25.</i>
1	Dima di flangiatura "60 DB" per tubazione CSST Eurotis DN 15 in acciaio inossidabile AISI 304 /AISI 316 L (acqua - solare - gas) e DN 12 in acciaio inossidabile AISI 304 (acqua - solare). <i>Template "60 DB" for DN 15 AISI 304 and AISI 316L PLT-CSST tube DN 12 AISI 304 PLT-CSST tube.</i>
1	Dima di flangiatura "60 DB" per tubazione CSST Eurotis DN 15 in acciaio inossidabile AISI 304 /AISI 316 L (acqua - solare - gas) e DN 12 in acciaio inossidabile AISI 316 L (gas). <i>Template "60 DB" for DN 15 AISI 304 and AISI 316L PLT-CSST tube DN 12 AISI 316L PLT-CSST tube.</i>
10	Dadi DN 12 in ottone nichelato a sede speciale con filettatura femmina G 1/2 e guarnizioni piane KLINGERSIL C4324 idonee al trasporto di acqua potabile e resistenti ad alte temperature operative continue. <i>Nickel plated brass nuts with special seat and ISO 228 G female thread with synthetic fibers KLINGERSIL C4324 plane gaskets suitable for drinking water and resistant to high continuous working temperatures - DN 12 (G 1/2).</i>
10	Dadi DN 15 in ottone nichelato a sede speciale con filettatura femmina G 3/4 e guarnizioni piane KLINGERSIL C4324 idonee al trasporto di acqua potabile e resistenti ad alte temperature operative continue. <i>Nickel plated brass nuts with special seat and ISO 228 G female thread with synthetic fibers KLINGERSIL C4324 plane gaskets suitable for drinking water and resistant to high continuous working temperatures - DN 15 (G 3/4).</i>
10	Dadi DN 12 in ottone nichelato a sede speciale con filettatura femmina G 1/2 e guarnizioni piane in NBR a norma EN 682 per gas. <i>Nickel plated brass nuts with special seat and ISO 228 G female thread with NBR plane gaskets conform to EN 682 standard for gas - DN 12 (G 1/2).</i>
10	Dadi DN 15 in ottone nichelato a sede speciale con filettatura femmina G 3/4 e guarnizioni piane in NBR a norma EN 682 per gas. <i>Nickel plated brass nuts with special seat and ISO 228 G female thread with NBR plane gaskets conform to EN 682 standard for gas - DN 15 (G 3/4).</i>





## PLUS KIT

N° pz. pcs.	Descrizione - Description
1	Valigetta metallo / Metal tool case.
1	Attrezzo di flangiatura manuale "60 DB" per tubazioni Eurotis. <i>Manual flanging tool "60 DB".</i>
1	Tagliatubo per tubazioni CSST Eurotis da DN 10 a DN 25. <i>PLT-CSST tube cutter from DN 10 to DN 25.</i>
1	Dima di flangiatura "60 DB" per tubazione CSST Eurotis DN 10 in acciaio inox AISI 304 (acqua) e DN 12 in acciaio inox AISI 304 (acqua - solare). <i>Template "60 DB" for DN 10 AISI 304 and AISI 316L PLT-CSST tube DN 12 AISI 304 PLT-CSST tube.</i>
1	Dima di flangiatura "60 DB" per tubazione CSST Eurotis DN 15 in acciaio inox AISI 304 / AISI 316 L (acqua - solare - gas) e DN 12 in acciaio inox AISI 316 L (gas). <i>Template "60 DB" for DN 10 AISI 304 PLT-CSST tube DN 12 AISI 316L PLT-CSST tube.</i>
1	Dima di flangiatura "60 DB" per tubazione CSST Eurotis DN 20 in acciaio inox AISI 304 / AISI 316 L (acqua - solare - gas) e DN 25 in acciaio inox AISI 304 / AISI 316 L (acqua - solare - gas). <i>Template "60 DB" for DN 20 DN 25 for AISI 304/AISI 316L PLT-CSST tube.</i>
10	Dadi DN 10 in ottone nichelato a sede speciale con fil.femmina G 3/8" e guarnizioni piane KLINGERSIL C4324 idonee al trasporto di acqua potabile e resistenti ad alte temperature operative continue. <i>Nickel plated brass nuts with special seat and ISO 228 G female thread with synthetic fibers KLINGERSIL C4324 plane gaskets suitable for drinking water and resistant to high continuous working temperatures - DN 10 (G 3/8").</i>
20	Dadi DN 12 in ottone nichelato a sede speciale con fil.femmina G 1/2 e guarnizioni piane KLINGERSIL C4324 idonee al trasporto di acqua potabile e resistenti ad alte temperature operative continue. <i>Nickel plated brass nuts with special seat and ISO 228 G female thread with synthetic fibers KLINGERSIL C4324 plane gaskets suitable for drinking water and resistant to high continuous working temperatures - DN 12 (G 1/2).</i>
20	Dadi DN 15 in ottone nichelato a sede speciale con fil.femmina G 3/4 e guarnizioni piane KLINGERSIL C4324 idonee al trasporto di acqua potabile e resistenti ad alte temperature operative continue. <i>Nickel plated brass nuts with special seat and ISO 228 G female thread with synthetic fibers KLINGERSIL C4324 plane gaskets suitable for drinking water and resistant to high continuous working temperatures - DN 15 (G 3/4).</i>
10	Dadi DN 20 in ottone nichelato a sede speciale con fil.femmina G 1 e guarnizioni piane KLINGERSIL C4324 idonee al trasporto di acqua potabile e resistenti ad alte temperature operative continue. <i>Nickel plated brass nuts with special seat and ISO 228 G female thread with synthetic fibers KLINGERSIL C4324 plane gaskets suitable for drinking water and resistant to high continuous working temperatures - DN 20 (G 1).</i>
10	Dadi DN 25 in ottone nichelato a sede speciale con fil.femmina G 1 1/4 e guarnizioni piane KLINGERSIL C4324 idonee al trasporto di acqua potabile e resistenti ad alte temperature operative continue. <i>Nickel plated brass nuts with special seat and ISO 228 G female thread with synthetic fibers KLINGERSIL C4324 plane gaskets suitable for drinking water and resistant to high continuous working temperatures - DN 25 (G 1 1/4).</i>



## STARTER KIT con attrezzo di flangiatura manuale e tubazioni CSST

STARTER KIT with manual flanging tool and PLT-CSST tubes

Codice Code	N° kit/ conf. N° kit/ pack	CHF/ con- fez. CHF/ pack
A06-0001-03149	1	536,40

N° pz. pcs.	Descrizione - Description
1 (5 m)	Tubo CSST DN 12 in acciaio inox AISI 316L spessore 0,30 mm con rivestimento protettivo giallo in LDPE a norma EN 15266 per impianti gas. <i>Pliable corrugated PLT-CSST tube in AISI 316L stainless steel 0,30 mm thick, for gas supply with LDPE protective yellow coating conform to EN 15266 standard - DN 12.</i>
1 (5 m)	Tubo CSST DN 15 in acciaio inox AISI 316L spessore 0,30 mm con rivestimento protettivo giallo in LDPE a norma EN 15266 per impianti gas. <i>Pliable corrugated PLT-CSST tube in AISI 316L stainless steel 0,30 mm thick, for gas supply with LDPE protective yellow coating conform to EN 15266 standard - DN 15.</i>
1 (4 m)	Tubo CSST DN 12 in acciaio inox AISI 304 spessore 0,30 mm idoneo al trasporto di acqua potabile. <i>Pliable corrugated PLT-CSST tube in AISI 304 stainless steel 0,30 mm thick, suitable for drinking water - DN 12.</i>
1 (4 m)	Tubo CSST DN 15 in acciaio inox AISI 304 spessore 0,30 mm idoneo al trasporto di acqua potabile. <i>Pliable corrugated PLT-CSST tube in AISI 304 stainless steel 0,30 mm thick, suitable for drinking water - DN 15.</i>
1	Valigetta polipropilene / <i>Polypropylene tool case</i>
1	Attrezzo di flangiatura manuale "60 DB" per tubazioni CSST Eurotis. <i>Manual flanging tool "60 DB"</i>
1	Tagliatubo per tubazioni CSST Eurotis da DN 10 a DN 25. <i>PLT-CSST tube cutter from DN 10 to DN 25.</i>
1	Dima di flangiatura "60 DB" per tubazione CSST Eurotis DN 12 in acciaio inox AISI 316L (gas) e DN 15 in acciaio inox AISI 304/AISI 316 L (acqua - solare - gas). <i>Template "60 DB" for DN 15 AISI 304 and AISI 316L PLT-CSST-PLT tube DN 12 AISI 316L PLT-CSST tube.</i>
1	Dima di flangiatura "60 DB" per tubazione CSST Eurotis DN 12 in acciaio inox AISI 304 (acqua - solare) e DN 15 in acciaio inox AISI 304 / AISI 316L (acqua - solare - gas). <i>Template "60 DB" for DN 15 AISI 304 and AISI 316L PLT-CSST tube DN 12 AISI 304 PLT-CSST tube.</i>
10	Dadi DN 12 in ottone nichelato a sede speciale con fil.femmina G 1/2 e guarnizioni piane KLINGERSIL C4324 idonee al trasporto di acqua potabile e resistenti ad alte temperature operative continue. <i>Nickel plated brass nuts with special seat and ISO 228 G female thread with synthetic fibers KLINGERSIL C4324 plane gaskets suitable for drinking water and resistant to high continuous working temperatures - DN 12 (G 1/2).</i>
10	Dadi DN 15 in ottone nichelato a sede speciale con fil.femmina G 3/4 e guarnizioni piane KLINGERSIL C4324 idonee al trasporto di acqua potabile e resistenti ad alte temperature operative continue. <i>Nickel plated brass nuts with special seat and ISO 228 G female thread with synthetic fibers KLINGERSIL C4324 plane gaskets suitable for drinking water and resistant to high continuous working temperatures - DN 15 (G 3/4).</i>
10	Dadi DN 12 in ottone nichelato a sede speciale con fil. femmina G 1/2 e guarnizioni piane in NBR a norma EN 682 per gas. <i>Nickel plated brass nuts with special seat and ISO 228 G female thread with NBR plane gaskets conform to EN 682 standard for gas - DN 12 (G 1/2).</i>
10	Dadi DN 15 in ottone nichelato a sede speciale con fil. femmina G 3/4 e guarnizioni piane in NBR a norma EN 682 per gas. <i>Nickel plated brass nuts with special seat and ISO 228 G female thread with NBR plane gaskets conform to EN 682 standard for gas - DN 15 (G 3/4).</i>
1	Nastro protettivo in silicone autovulcanizzante giallo. <i>Yellow protective self-vulcanizing siliconic tape.</i>



## STARTER KIT con attrezzo ADAPTOR e tubazioni CSST

STARTER KIT with ADAPTOR flanging tool and PLT-CSST tubes

Codice Code	N° kit/ conf. N° kit/ pack	CHF/confez. CHF/pack
A06-0001-05346	1	685,70

N° pz. pcs.	Descrizione - Description
1 (5 m)	Tubo CSST DN 12in acciaio inox AISI 316L spessore 0,30 mm con riv. protettivo giallo in LDPE a norma EN 15266 per impianti gas. <i>Pliable corrugated PLT-CSST tube in AISI 316L stainless steel 0,30 mm thick, for gas supply with LDPE protective yellow coating conform to EN 15266 standard - DN 12.</i>
1 (5 m)	Tubo CSST DN 15 in acciaio inox AISI 316L spessore 0,30 mm con riv. protettivo giallo in LDPE a norma EN 15266 per impianti gas. <i>Pliable corrugated PLT-CSST tube in AISI 316L stainless steel 0,30 mm thick, for gas supply with LDPE protective yellow coating conform to EN 15266 standard - DN 15.</i>
1 (4 m)	Tubo CSST DN 12 in acciaio inox AISI 304 spessore 0,30 mm idoneo al trasporto di acqua potabile. <i>Pliable corrugated PLT-CSST tube in AISI 304 stainless steel 0,30 mm thick, suitable for drinking water - DN 12.</i>
1 (4 m)	Tubo CSST DN 15 in acciaio inox AISI 304 spessore 0,30 mm idoneo al trasporto di acqua potabile. <i>Pliable corrugated PLT-CSST tube in AISI 304 stainless steel 0,30 mm thick, suitable for drinking water - DN 15.</i>
1	Valigetta polipropilene / <i>Polypropylene tool case.</i>
1	ADAPTOR: Attrezzo di flangiatura "60 DB" per tubazioni CSST Eurotis adattabile ad ogni tipo di macchina pressatrice. <i>ADAPTOR - Automatic flanging tool adaptable to any type of pressing machine.</i>
1	Tagliatubo per tubazioni CSST Eurotis da DN 10 a DN 25. <i>PLT-CSST tube cutter from DN 10 to DN 25.</i>
1	Dima di flangiatura "60 DB" per tubazione CSST Eurotis DN 12 in acciaio inox AISI 316 L (gas) e DN 15 in acciaio inox AISI 304/AISI 316L (acqua - solare - gas). <i>Template "60 DB" for DN 15 AISI 304 and AISI 316L PLT-CSST tube DN 12 AISI 316L PLT-CSST tube.</i>
1	Dima di flangiatura "60 DB" per tubazione CSST Eurotis DN 12 in acciaio inox AISI 304 (acqua - solare ) e DN 15 in acciaio inox AISI 304 / AISI 316 L (acqua - solare - gas). <i>Template "60 DB" for DN 15 AISI 304 and AISI 316L PLT-CSST tube DN 12 AISI 304 PLT-CSST tube.</i>
10	Dadi DN 12 in ottone nichelato a sede speciale con filettatura femmina G 1/2 e guarnizioni piane KLINGERSIL C4324 idonee al trasporto di acqua potabile e resistenti ad alte temperature operative continue. <i>Nickel plated brass nuts with special seat and ISO 228 G female thread with synthetic fibers KLINGERSIL C4324 plane gaskets suitable for drinking water and resistant to high continuous working temperatures - DN 12 (G 1/2).</i>
10	Dadi DN 15 in ottone nichelato a sede speciale con filettatura femmina G 3/4 e guarnizioni piane KLINGERSIL C4324 idonee al trasporto di acqua potabile e resistenti ad alte temperature operative continue. <i>Nickel plated brass nuts with special seat and ISO 228 G female thread with synthetic fibers KLINGERSIL C4324 plane gaskets suitable for drinking water and resistant to high continuous working temperatures - DN 15 (G 3/4).</i>
10	Dadi DN 12 in ottone nichelato a sede speciale con filettatura femmina G 1/2 e guarnizioni piane in NBR a norma EN 682 per gas. <i>Nickel plated brass nuts with special seat and ISO 228 G female thread with NBR plane gaskets conform to EN 682 standard for gas - DN 12 (G 1/2).</i>
10	Dadi DN 15 in ottone nichelato a sede speciale con filettatura femmina G 3/4 e guarnizioni piane in NBR a norma EN 682 per gas. <i>Nickel plated brass nuts with special seat and ISO 228 G female thread with NBR plane gaskets conform to EN 682 standard for gas - DN 15 (G 3/4).</i>
1	Nastro protettivo in silicone autovulcanizzante giallo. <i>Yellow protective self-vulcanizing siliconic tape.</i>

## Attrezzature per sistema a pressare

Tools for press-fitting system

Da DN 12 a DN 25



Ganascia di pressatura a profilo E (brevettato) per sistema ePRESS  
E-profile pressing jaw (patented) for ePRESS system

Codice Code	DN	Per tubo - For tube		Applicazione - Application			Pz./conf. Pcs./pack	CHF/confez. CHF/pack	Conf./box Packs/box
		AISI 304	AISI 316L						
A06-0001-05152	12		●	●		●	1	320,70	1
A06-0001-05153	15	●	●	●	●	●	1	320,70	1
A06-0001-05154	20	●	●	●	●	●	1	320,70	1
A06-0001-05155	25	●	●	●	●	●	1	445,50	1

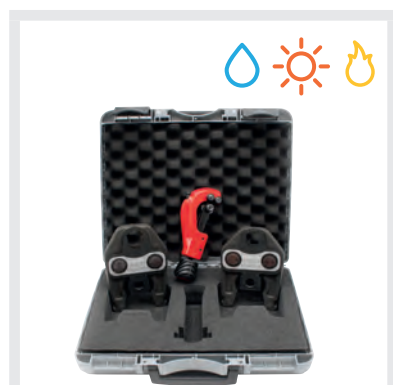

Kit ePRESS DN 12-15

Codice Code	N° kit/conf. N° kit/pack	CHF/confez. CHF/pack
A06-0001-06678	1	786,40

N° pz. / pcs.	Descrizione - Description
1	Valigetta polipropilene / Polypropylene tool case.
1	Tagliatubo per tubazioni CSST Eurotis da DN 10 a DN 25. PLT-CSST tube cutter from DN 10 to DN 25.
1	Ganascia di pressatura a profilo E (brevettato) per tubazioni CSST Eurotis - DN 12. E-profile pressing jaw (patented) for PLT-CSST tubes DN 12.
1	Ganascia di pressatura a profilo E (brevettato) per tubazioni CSST Eurotis - DN 15. E-profile pressing jaw (patented) for PLT-CSST tubes DN 15.



Kit ePRESS DN 15-20

N° pz. / pcs.	Descrizione - Description
1	Valigetta polipropilene / Polypropylene tool case.
1	Tagliatubo per tubazioni CSST Eurotis da DN 10 a DN 25. <i>PLT-CSST tube cutter from DN 10 to DN 25.</i>
1	Ganascia di pressatura a profilo E (brevettato) per tubazioni CSST Eurotis - DN 15. <i>E-profile pressing jaw (patented) for PLT-CSST tubes DN 15.</i>
1	Ganascia di pressatura a profilo E (brevettato) per tubazioni CSST Eurotis - DN 20. <i>E-profile pressing jaw (patented) for PLT-CSST tubes DN 20.</i>

## Accessori

### Accessories



Valvola d'intercettazione gas "a leva" dotata di 2 staffe e viti di fissaggio protezione da cantiere. Per tutti i tipi di gas (EN 437 / DVGW G260/1).

*Lever interception valve for gas plants with 2 brackets and fixing screws for construction site protection. For all types of gas (EN 437 / DVGW G260/1).*

Codice Code	Norme di riferimento Standards	Pressione di esercizio Working pressure	Temp. di esercizio Working temperature	Connessioni Connections	Resistenza termica Thermal resistance	CHF/confez. CHF/pack	Pz./conf. Pcs./pack
A08-0001-06451	EN 331	MOP 1	-20°C +60°C	G 3/4 Battuta piana Plane end	HTB GT 0.1 650°C x 30'	71,50	1

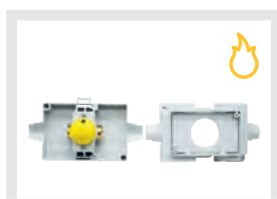

Valvola d'intercettazione gas "dritta" dotata di 2 staffe e viti di fissaggio protezione da cantiere. Per tutti i tipi di gas (EN 437 / DVGW G260/1).

*Straight interception valve for gas plants with 2 brackets and fixing screws for construction site protection. For all types of gas (EN 437 / DVGW G260/1).*

Codice Code	Norme di riferimento Standards	Pressione di esercizio Working pressure	Temp. di esercizio Working temperature	Connessioni Connections	Resistenza termica Thermal resistance	Dotazione standard Standard equipment	CHF/confez. CHF/pack	Pz./conf. Pcs./pack
A08-0001-06450	EN 331	MOP 1	-20°C +60°C	G 3/4 Battuta piana Plane end	HTB GT 0.1 650°C x 30'		67,30	1

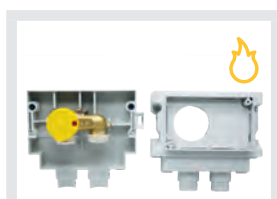

Valvola d'intercettazione gas a "U" dotata di 2 staffe e viti di fissaggio protezione da cantiere. Per tutti i tipi di gas (EN 437 / DVGW G260/1).

*"U" interception valve for gas plants with 2 brackets and fixing screws for construction site protection. For all types of gas (EN 437 / DVGW G260/1).*

Codice Code	Norme di riferimento Standards	Pressione di esercizio Working pressure	Temp. di esercizio Working temperature	Connessioni Connections	Resistenza termica Thermal resistance	CHF/confez. CHF/pack	Pz./conf. Pcs./pack
A08-0001-06449	EN 331	MOP 1	-20°C +60°C	G 3/4 Battuta piana Plane end	HTB GT 0.1 650°C x 30'	76,10	1



**Placca cromata per valvole d'intercettazione gas**  
*Chromed plate for interception valves for gas plants*

Codice Code	Dimensioni Dimensions	Applicazione Application			Pz./conf. Pcs./pack	CHF/confez. CHF/pack	Confez. Pack
							
A07-0001-06586	135 x 90 mm				1	22,20	1



**Adattatore filettato per valvole di intercettazione gas**  
*Thread adapter for interception valves for gas plants*

Codice Code	Fil connessione Connection thread	Applicazione Application			Pz./conf. Pcs./pack	CHF/confez. CHF/pack	Confez. Pack
							
A03-0001-06453	1/2"				1	8,70	1



**Adattatore per valvole d'intercettazione gas per raccordi a tenuta piana**  
*Adapter plane end fittings for interception valves for gas plants*

Codice Code	Fil connessione Connection thread	Applicazione Application			Pz./conf. Pcs./pack	CHF/confez. CHF/pack	Confez. Pack
							
A03-0001-06452	G 3/4"				1	3,30	1

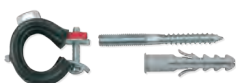

**Collari in acciaio zincato a fissaggio automatico per tubazioni CSST completi di viti e tasselli**  
*Automatic fixing clamps in galvanized steel for PLT-CSST tubes supplied with plugs and screws*

Codice Code	DN	Per tubo For tube		Applicazione Application			Pz./conf. Pcs./pack	CHF/confez. CHF/pack	Confez. Pack
		AISI 304	AISI 316L	Water	Sun	Fire			
A09-0002-01803	12	●	●	●		●	2	9,90	1
A09-0002-01804	15	●	●	●		●	2	10,20	1
A09-0002-01805	20	●	●	●		●	2	10,20	1
A09-0002-01806	25	●	●	●		●	2	14,50	1
A09-0002-04871	32	●	●	●		●	2	18,90	1
A09-0002-04872	40	●	●	●		●	2	20,20	1
A09-0002-04873	50	●	●	●		●	2	21,90	1



**Collari ovali di fissaggio in acciaio zincato per tubazioni binate EUROSOLAR completi di viti e tasselli**  
*Oval clamps in galvanized steel for double solar tubes supplied with plugs and screws*

Codice Code	Per tubo For tube			Applicazione Application			Pz./conf. Pcs./pack	CHF/confez. CHF/pack	Confez. Pack
	Twin Solar Set	SolarThin Power	SolarPRESS	Water	Sun	Fire			
A09-0004-01562	DN 12	DN 15	DN 15		●		4	31,10	1
A09-0004-01563	DN 15	DN 20	DN 20		●		4	31,10	1
A09-0004-01564	DN 20	DN 25	DN 25		●		4	31,10	1
A09-0004-01751	DN 25	-	-		●		4	31,10	1



**Piastre di fissaggio a muro in ottone nichelato con alloggiamento per dado**  
*Nickel plated brass wall plates with nut seat*

Codice Code	DN	Per tubo For tube		Applicazione Application			Pz./conf. Pcs./pack	CHF/confez. CHF/pack	Confez. Pack
		AISI 304	AISI 316L	Water	Sun	Fire			
A03-0001-00810	12		●			●	1	10,70	1
A03-0001-00811	15		●			●	1	14,40	1





**Fascette di centraggio in poliammide PA66 (nylon) autoestinguente di colore giallo**  
*Polyamide PA66 (nylon) autoextinguishing yellow coloured centering spacers*

Codice Code	DN	Per tubo For tube		Applicazione Application			Pz./conf. Pcs./pack	CHF/confez. CHF/pack	Confez. Pack
		AISI 304	AISI 316L	Water	Sun	Fire			
A09-0050-01929	12-15		●			●	50	61,30	1
A09-0050-01930	20-25		●			●	50	61,30	1
A09-0050-04266	32-40		●			●	50	122,60	1
A09-0050-04267	50		●			●	50	122,60	1



**Nastro protettivo in silicone autovulcanizzante giallo**  
*Yellow protective self-vulcanizing siliconic tape*

Codice Code	Altezza Height	Spessore Thickness	Lunghezza Length	Applicazione Application			Pz./conf. Pcs./pack	CHF/confez. CHF/pack	Confez. Pack
				Water	Sun	Fire			
A07-0001-06775	25,4 mm	0,5 mm	3 m			●	1	22,40	1



**Nastro metallico con fori per fissaggio di tubi CSST**  
*Metallic punched tape for fastening of PLT-CSST tubes inside the buildings*

Codice Code	Altezza Height	Spessore Thickness	Lunghezza Length	Ø fori Ø holes	Applicazione Application			Pz./conf. Pcs./pack	CHF/confez. CHF/pack	Confez. Pack
					Water	Sun	Fire			
A09-0001-01789	19 mm	0,75 mm	10 m	6,3 mm	●	●		1	62,80	1

## Ricambi Spare parts



Lame di ricambio per tagliatubo A06-0001-05409

Spare blades for A06-0001-05409 tube cutter

Codice Code	Per tagliatubo For tube cutter	Applicazione - Application			Pz./conf. Pcs./pack	CHF/confez. CHF/pack	Conf./box Packs/box
A06-0005-05538	A06-0001-05409				5	79,40	-

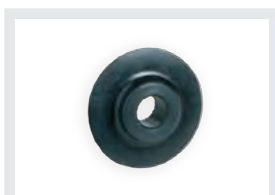

Lama di ricambio per tagliatubi A06-0001-05070 e A06-0001-7500

Spare blade for tube cutters A06-0001-05070 e A06-0001-7500

Codice Code	Per tagliatubo For tube cutter	Applicazione - Application			Pz./conf. Pcs./pack	CHF/confez. CHF/pack	Conf./box Packs/box
A06-0001-05540	A06-0001-05070				1	16,40	-



Batteria di ricambio per attrezzo automatico di flangiatura REMS

Spare battery for automatic flanging tool

Codice Code	Per attrezzo For tool	Pz./conf. Pcs./pack	CHF/confez. CHF/pack	Conf./box Packs/box
A06-0001-04609	A06-0001-04610	1	358,00	-



Kit di ricambio per dime di flangiatura "60DB" per tubazioni CSST Eurotis

Spare parts for flanging template "60DB" for PLT-CSST tubes

Codice Code	Per dima For template	Applicazione - Application			Pz./conf. Pcs./pack	CHF/confez. CHF/pack	Conf./box Packs/box
A06-0001-05539	"60 DB"				1	24,30	-



**Valigetta in alluminio**  
*Alluminium tool case*

Codice Code	Dimensioni / Dimensions (cm)			Pz./conf. Pcs./pack	CHF/confez. CHF/pack	Conf./box Packs/box
	H	L	P			
A06-0001-02169	33	45	16	1	<b>136,50</b>	1



**Valigetta in polipropilene**  
*Polypropylene tool case*

Codice Code	Dimensioni / Dimensions (cm)			Pz./conf. Pcs./pack	CHF/confez. CHF/pack	Conf./box Packs/box
	H	L	P			
A06-0001-01969	30	38	10	1	<b>50,50</b>	8



**Macchina per svolgere, tagliare e riavvolgere tubi CSST**  
*Machine to un-roll, cut and roll-up the PLT-CSST tubes*

Codice Code	Dimensioni / Dimensions (cm)		Pz./conf. Pcs./pack	CHF/confez. CHF/pack	Conf./box Packs/box
	H	L			
A06-0001-04201	90	280	1	<b>7.518,00</b>	1



**Svolgitubo CSST su bobine di legno**  
*Un-roll device for PLT-CSST tubes on wooden coils*

Codice Code	Dimensioni / Dimensions (cm)		Pz./conf. Pcs./pack	CHF/confez. CHF/pack	Conf./box Packs/box
	H	L			
A06-0001-04858	120	140	1	<b>302,70</b>	1



Partner per professionisti

The page contains a series of horizontal lines for writing, spaced evenly across the middle and lower portions of the document.



*Partner per professionisti*

A series of horizontal lines for writing, spaced evenly down the page.



*Partner per professionisti*

**EUROTIS**  
Creatori di soluzioni

[www.eurotis.it](http://www.eurotis.it)

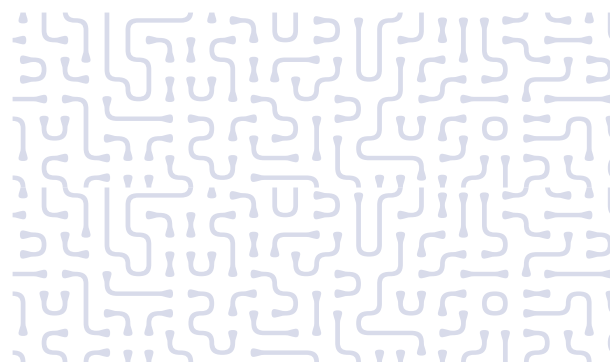

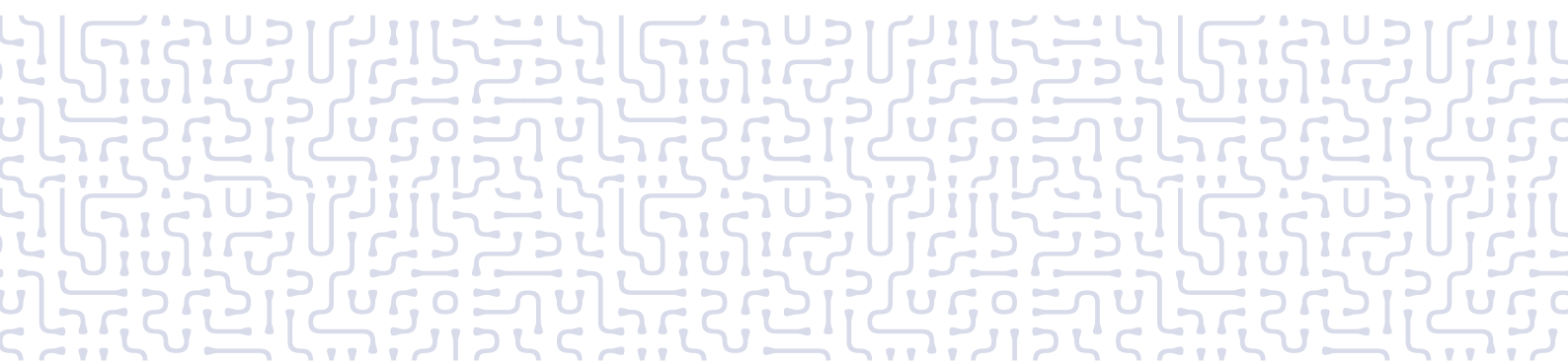

© Copyright Eurotis S.r.l. - Tutti i diritti riservati - Nessuna parte del testo o della grafica del presente manuale può essere riprodotta o trasmessa in qualsiasi forma o con qualsiasi mezzo, elettronico o meccanico, incluso le fotocopie, la trasmissione facsimile, la registrazione, il riadattamento o l'uso di qualsiasi sistema di immagazzinamento e recupero di informazioni, senza il permesso scritto di Eurotis S.r.l.

Eurotis S.r.l. non assume responsabilità per eventuali errori o inesattezze nel contenuto di questo prospetto e si riserva il diritto di apportare ai suoi prodotti, in qualunque momento e senza avviso, eventuali modifiche ritenute opportune per qualsiasi esigenza di carattere tecnico o commerciale. Questo prospetto non deve essere considerato come contratto nei confronti di terzi.



Partner per professionisti



### **CENTRO IDRO TERMO SANITARIO**

Prodotti per riscaldare, raffreddare, ventilare a 360°

### **SETTORE ENERGIE ALTERNATIVE**

Via Giovanni Varesi 18

CH-6600 Locarno

Tel. +41 091 756 06 08

[energie.alternative@frigerio.ch](mailto:energie.alternative@frigerio.ch)

**EUROTIS**  
Creatori di soluzioni

Eurotis srl

Via Quintino Sella n.1 ang. via Volta

20094 Corsico - MI

[info@eurotis.it](mailto:info@eurotis.it)

[www.eurotis.it](http://www.eurotis.it)

